

18A 200V N-channel Enhancement Mode Power MOSFET

1 Description

These N-channel enhanced vdmofets, is obtained by the self-aligned planar technology which reduce the conduction loss, improve switching performance and enhance the avalanche energy. Which accords with the RoHS standard.

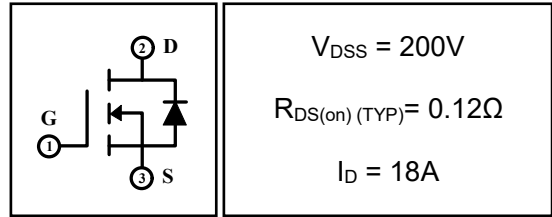

2 Features

- Fast switching
- Low on resistance($R_{dson} \leq 0.18\Omega$)
- Low gate charge(Typ: 16.4nC)
- Low reverse transfer capacitances(Typ: 20.4pF)
- 100% single pulse avalanche energy test
- 100% ΔV_{DS} test

3 Applications

- High efficiency switch mode power supplies.
- Power switch circuit of adaptor and charger.
- UPS
- Inverter



4 Electrical Characteristics

4.1 Absolute Maximum Rating ($T_C=25^\circ C$, unless otherwise noted)

| Parameter | Symbol | Rating | | Units | |
|--|-----------|-------------------------|------|------------|---|
| | | 640/I640/E640/B640/D640 | F640 | | |
| Drain-to-Source Voltage | V_{DSS} | 200 | | V | |
| Gate-to-Source Voltage | V_{GSS} | ± 30 | | V | |
| Continuous Drain Current | I_D | $T_C=25^\circ C$ | 18 | A | |
| | | $T_C=100^\circ C$ | 11.3 | A | |
| Pulsed Drain Current ⁽¹⁾ | I_{DM} | 72 | | A | |
| Single Pulse Avalanche Energy ⁽⁴⁾ | E_{AS} | 500 | | mJ | |
| Peak Diode Recovery dv/dt ⁽⁵⁾ | dv/dt | 5 | | V/ns | |
| Power Dissipation | P_{tot} | $T_a=25^\circ C$ | 2 | 2 | W |
| | | $T_C=25^\circ C$ | 100 | 35 | W |
| Isolation Voltage | V_{ISO} | / | 2500 | V | |
| Junction Temperature Range | T_j | -55~150 | | $^\circ C$ | |
| Storage Temperature Range | T_{stg} | -55~150 | | $^\circ C$ | |
| Maximum Temperature for soldering | T_L | 300 | | $^\circ C$ | |

4.2 Thermal Characteristics

| Parameter | Symbol | Rating | | Unit |
|---|------------|-------------------------|------|--------------|
| | | 640/I640/E640/B640/D640 | F640 | |
| Thermal Resistance, Junction to Case-sink | R_{thJC} | 1.25 | 3.57 | $^\circ C/W$ |
| Thermal Resistance, Junction to Ambient | R_{thJA} | 62.5 | 62.5 | $^\circ C/W$ |

4.3 Electrical Characteristics (T_c=25°C, unless otherwise noted)

| Parameter | Symbol | Test Condition | Value | | | Units |
|---|---------------------|--|-------|------|------|-------|
| | | | Min | Typ | Max | |
| Off Characteristics | | | | | | |
| Drain-to-Source Breakdown Voltage | BV _{DSS} | I _D =250μA, V _{GS} =0V | 200 | -- | -- | V |
| Drain-to-Source Leakage Current | I _{DSS} | V _{DS} =200V, V _{GS} =0V, T _C =25°C | -- | -- | 10 | μA |
| | | V _{DS} =160V, V _{GS} =0V, T _C =125°C | -- | -- | 100 | μA |
| Gate-to-Source Leakage Current | I _{GSS} | V _{GS} =±30V | -- | -- | ±100 | nA |
| On Characteristics | | | | | | |
| Gate Threshold Voltage | V _{GS(th)} | V _{DS} =V _{GS} , I _D =250μA | 2 | -- | 4 | V |
| Drain-to-Source on-state Resistance | R _{DS(on)} | V _{GS} =10V, I _D =9A | -- | 0.12 | 0.18 | Ω |
| Forward Transfer Conductance | g _{fs} | V _{DS} =15V, I _D =9A | -- | 8.5 | -- | S |
| Dynamic Characteristics | | | | | | |
| Input Capacitance | C _{iss} | V _{GS} =0V, V _{DS} =25V, f=1.0MHz | -- | 1136 | -- | pF |
| Output Capacitance | C _{oss} | | -- | 183 | -- | |
| Reverse Transfer Capacitance | C _{rss} | | -- | 16.4 | -- | |
| Switching Characteristics | | | | | | |
| Turn-on Delay Time | t _{d(on)} | I _D =18A, V _{DD} =100V, V _{GS} =10V, R _G =10Ω | -- | 19 | -- | nS |
| Turn-on Rise Time | t _r | | -- | 33 | -- | |
| Turn-off Delay Time | t _{d(off)} | | -- | 35 | -- | |
| Turn-off Fall Time | t _f | | -- | 8 | -- | |
| Total Gate Charge | Q _g | I _D =18A, V _{DD} =160V, V _{GS} =10V | -- | 20.4 | -- | nC |
| Gate-to-Source Charge | Q _{gs} | | -- | 6.9 | -- | |
| Gate-to-Drain("Miller") Charge | Q _{gd} | | -- | 7.3 | -- | |
| Drain-Source Diode Characteristics | | | | | | |
| Diode Forward Voltage ⁽³⁾ | V _{FSD} | V _{GS} =0V, I _S =18A | -- | -- | 1.5 | V |
| Diode Forward Current | I _S | | -- | -- | 18 | A |
| Reverse Recovery Time ⁽³⁾ | t _{rr} | T _J =25°C, I _F =18A, di _F /dt=100A/μS, V _{GS} =0V | -- | 187 | -- | nS |
| Reverse Recovery Charge ⁽³⁾ | Q _{rr} | | -- | 925 | -- | nC |

Notes:

- 1: Repetitive rating, pulse width limited by maximum junction temperature.
- 2: Surface mounted on FR4 Board, t_s≤10sec.
- 3: Pulse width ≤ 300μs, duty cycle ≤ 2%.
- 4: L=10mH, I_D=10A, V_{DD}=50V, V_{GATE}=200V, Start T_J=25°C.
- 5: I_{SD}=18A, di/dt≤100A/μs, V_{DD}≤BV_{DSS}, Start T_J=25°C.

5 Typical characteristics diagrams

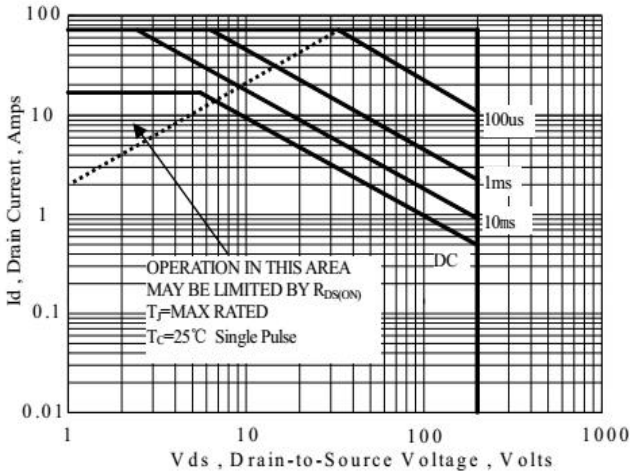

Figure 1 Maximum Forward Bias Safe Operating Area

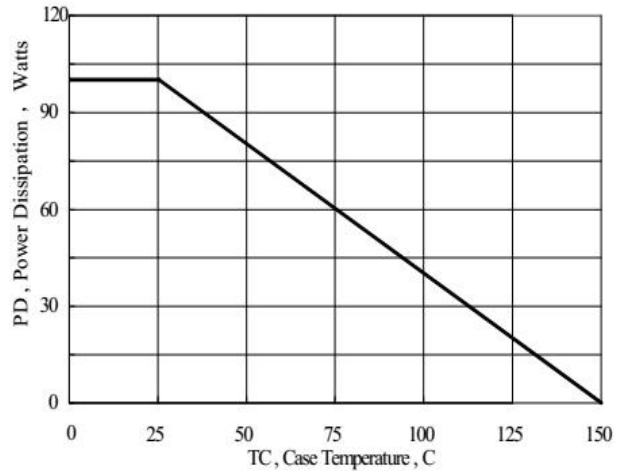

Figure 2 Maximum Power Dissipation vs Case Temperature

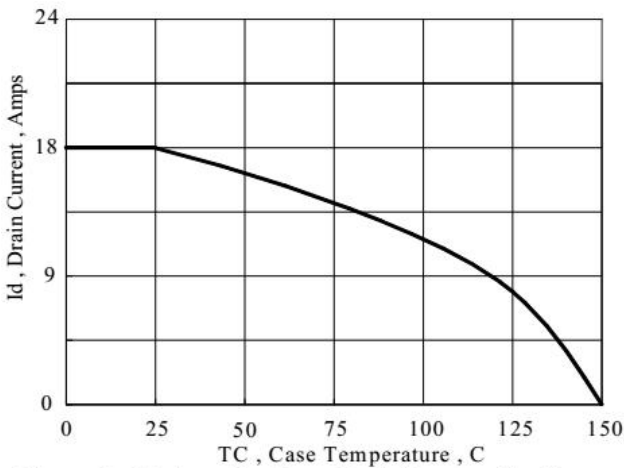

Figure 3 Maximum Continuous Drain Current vs Case Temperature

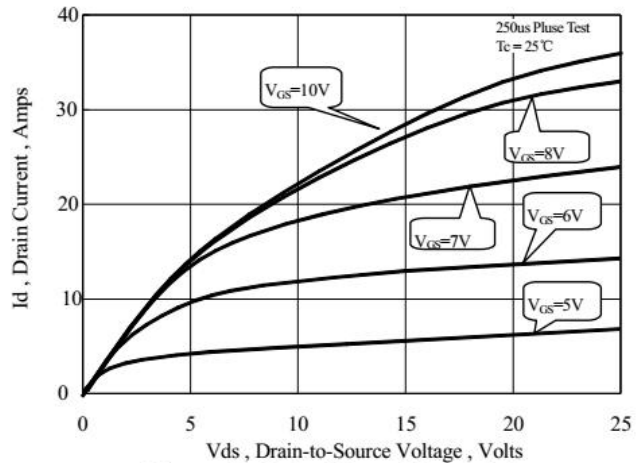

Figure 4 Typical Output Characteristics

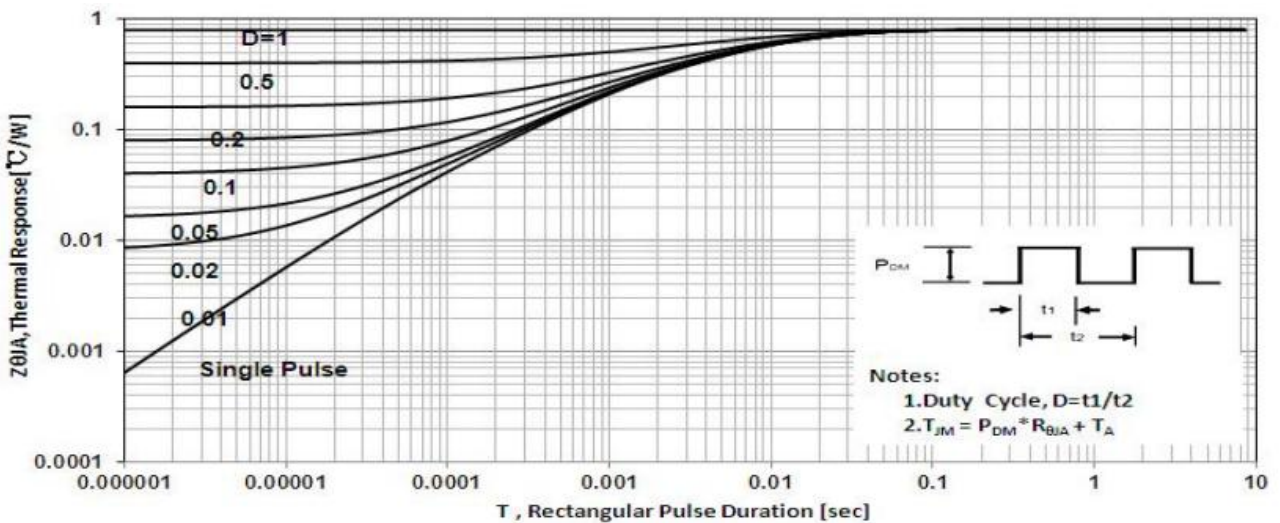

Figure 5 Maximum Effective Thermal Impedance, Junction to Case

5 Typical characteristics diagrams(continues)

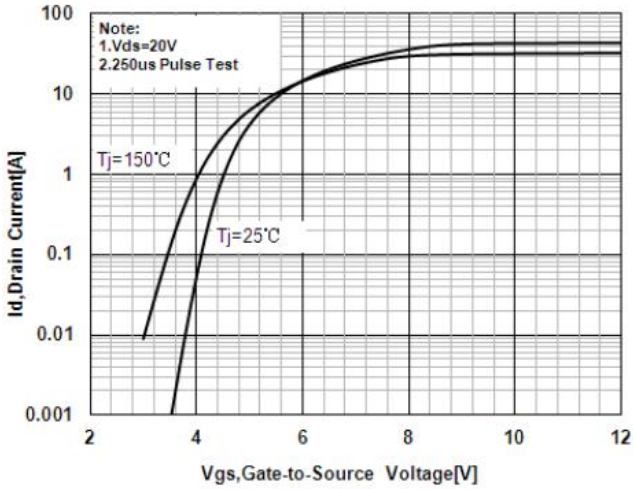

Figure 6 Typical Transfer Characteristics

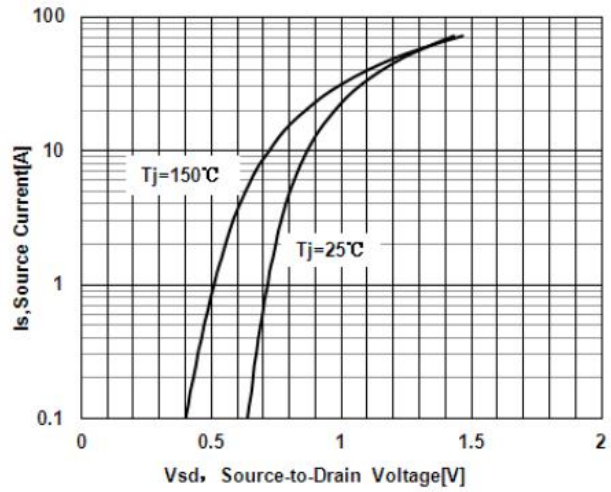

Figure 7 Typical Body Diode Transfer Characteristics

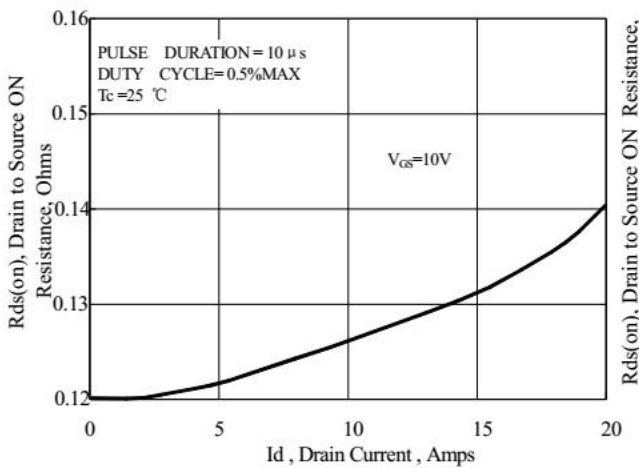

Figure 8 Typical Drain to Source ON Resistance vs Drain Current

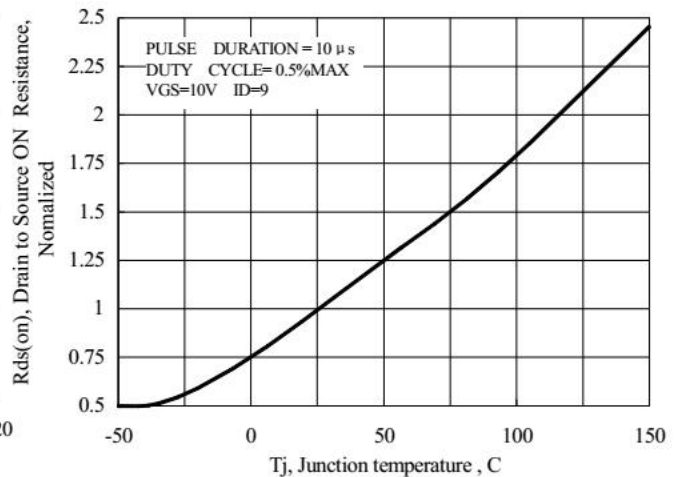

Figure 9 Typical Drain to Source on Resistance vs Junction Temperature

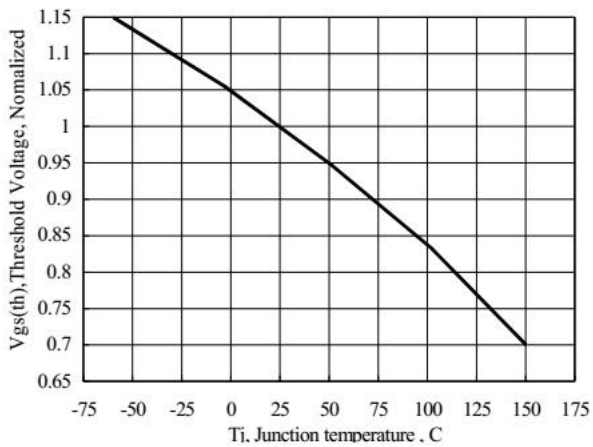

Figure 10 Typical Threshold Voltage vs Junction Temperature

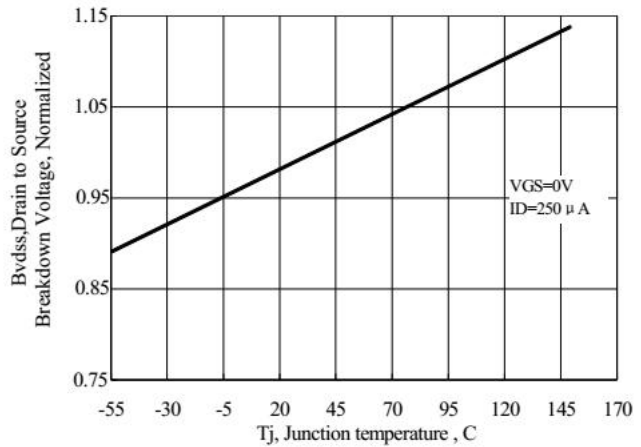

Figure 11 Typical Breakdown Voltage vs Junction Temperature

5 Typical characteristics diagrams(continues)

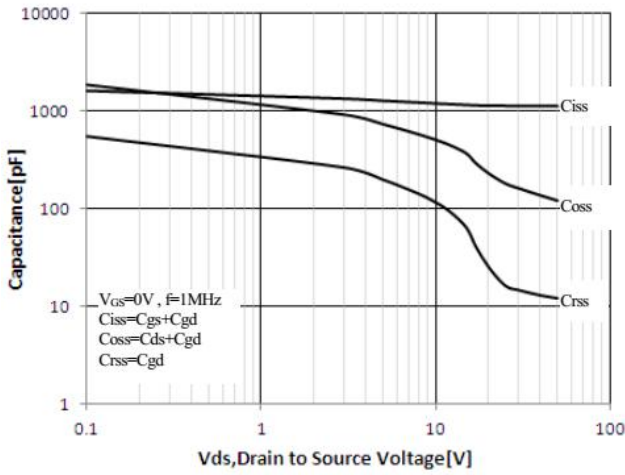

Figure 12 Typical Capacitance vs Drain to Source Voltage

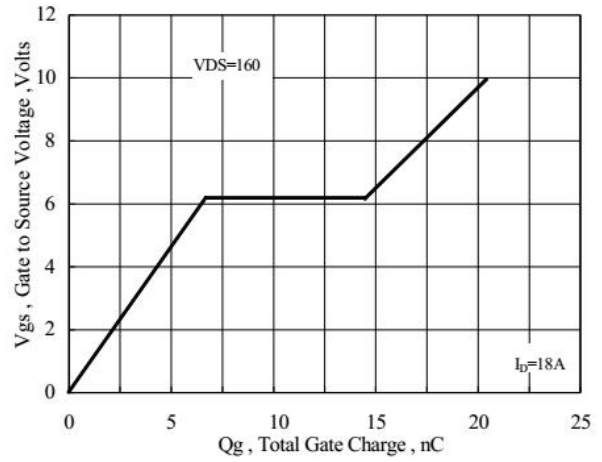

Figure 13 Typical Gate Charge vs Gate to Source Voltage

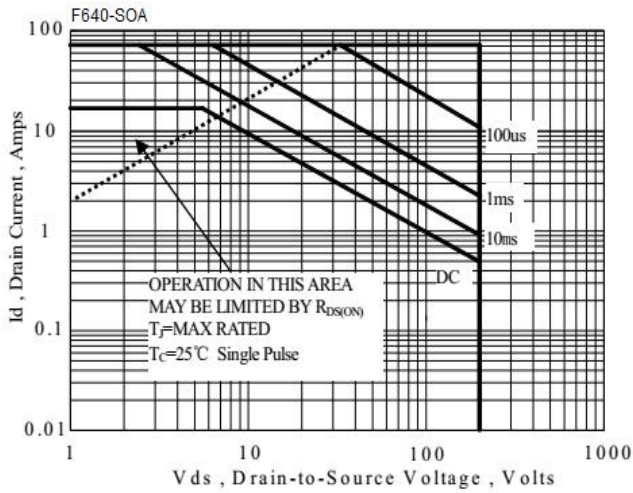

Figure 14 Maximum Forward Bias Safe Operating Area

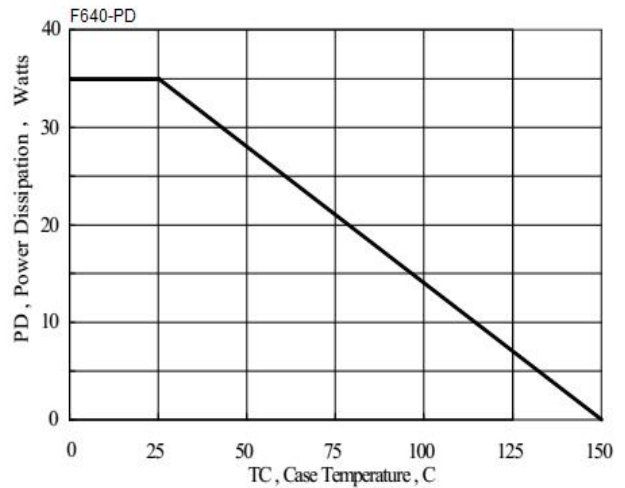
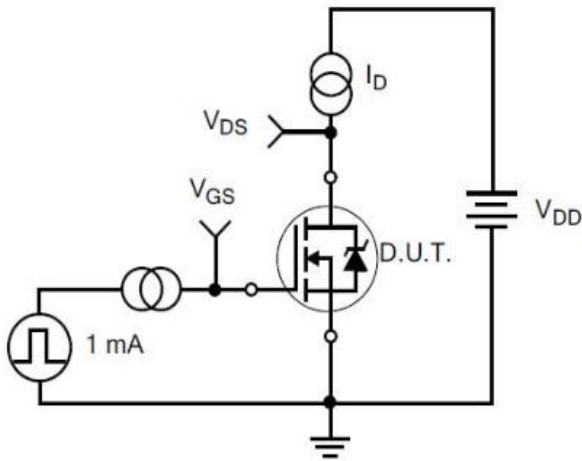
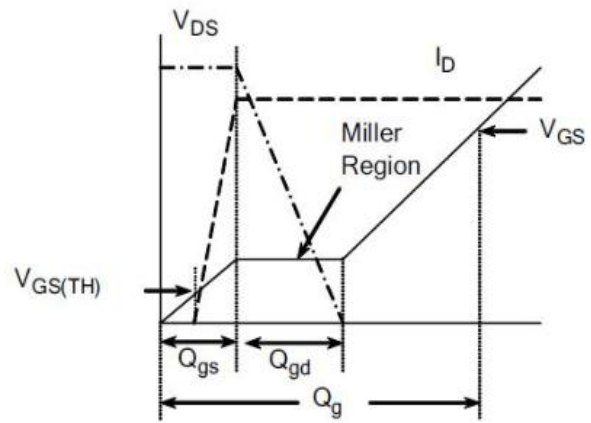

Figure 15 Maximum Power Dissipation vs Case Temperature

6 Typical Test Circuit and Waveform



1) Gate Charge Test Circuit



2) . Gate Charge Waveform

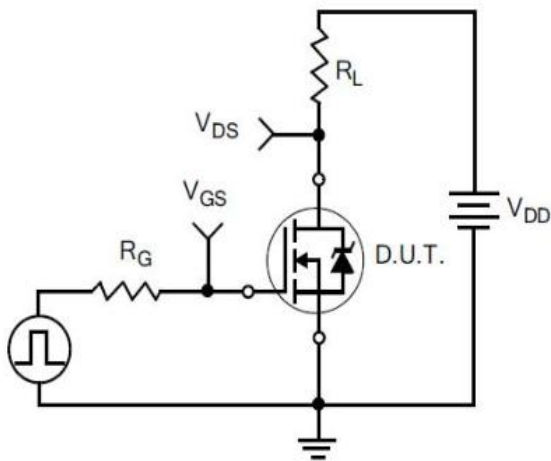

3) Resistive Switching Test Circuit

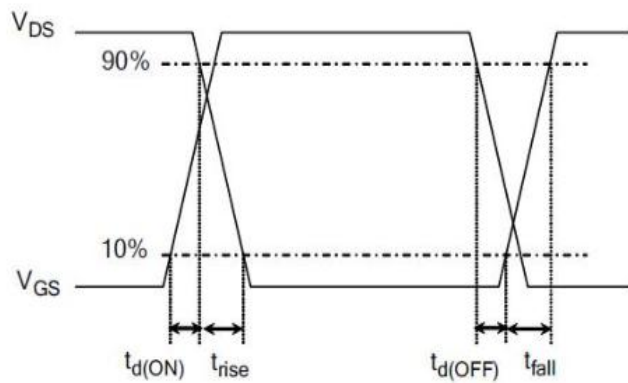

4) Resistive Switching Waveforms

6 Typical Test Circuit and Waveform(continues)

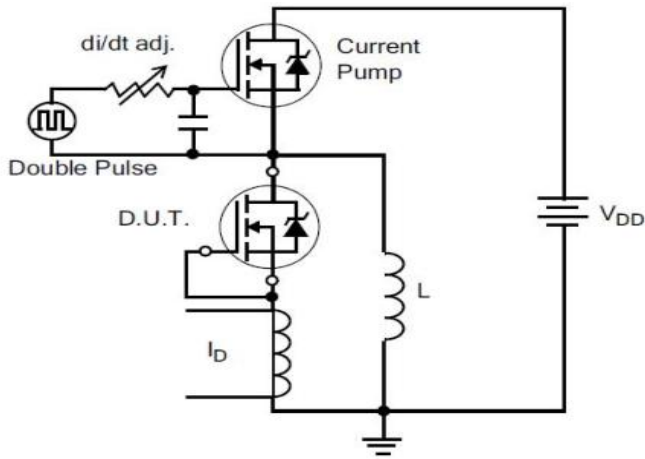

5) Diode Reverse Recovery Test Circuit

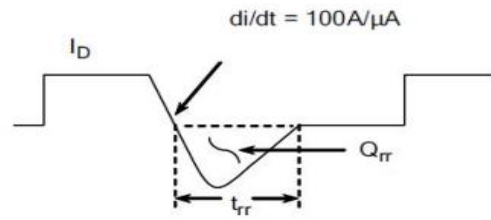

6) Diode Reverse Recovery Waveform

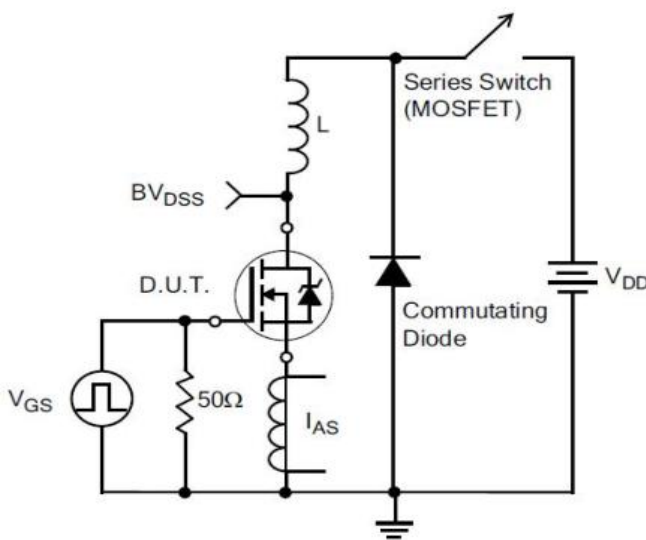

7) . Unclamped Inductive Switching Test Circuit

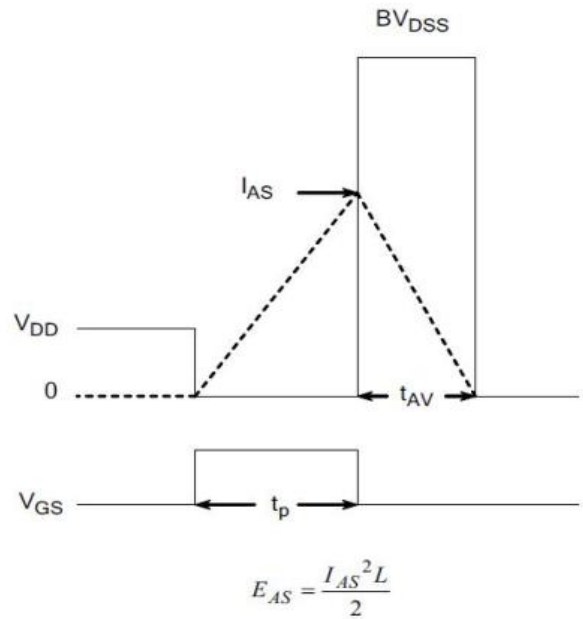

8) Unclamped Inductive Switching Waveforms

7 Product Names Rules

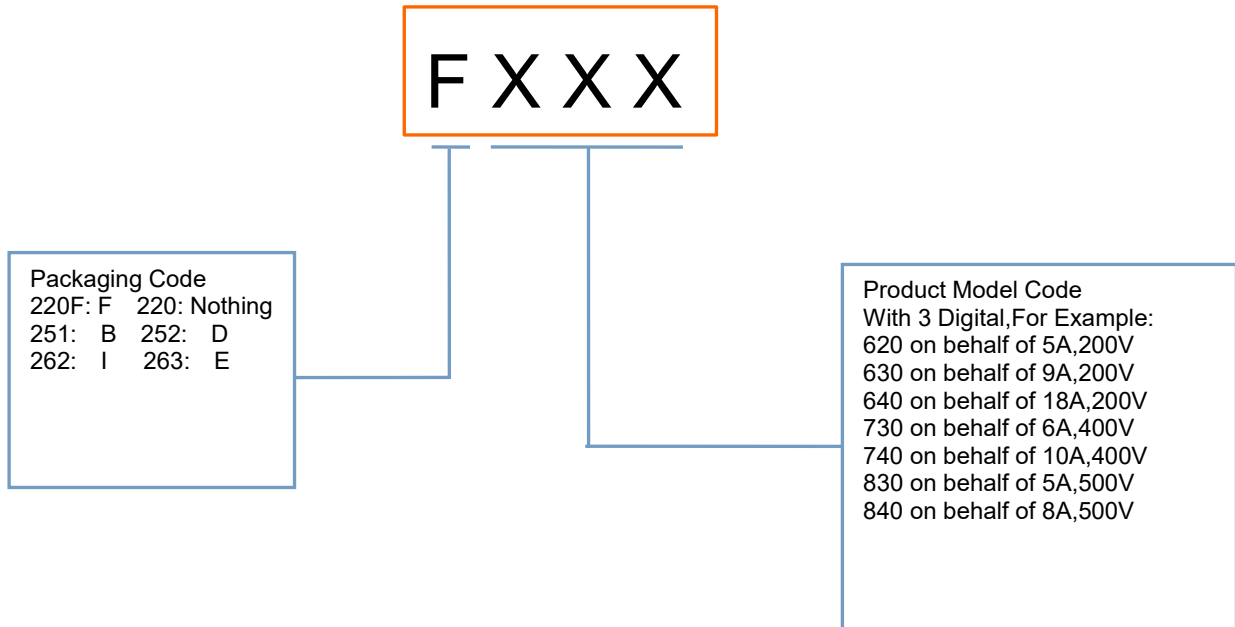

8 Product Specifications and Packaging Models

| Product Model | Package Type | Mark Name | RoHS | Package | Quantity |
|---------------|--------------|-----------|---------|-------------|----------|
| 640 | TO-220 | 640 | Pb-free | Tube | 1000/box |
| F640 | TO-220F | F640 | Pb-free | Tube | 1000/box |
| B640 | TO-251 | B640 | Pb-free | Tube | 3000/box |
| D640 | TO-252 | D640 | Pb-free | Tape & Reel | 2500/box |
| I640 | TO-262 | I640 | Pb-free | Tube | 1000/box |
| E640 | TO-263 | E640 | Pb-free | Tape & Reel | 800/box |

9 Dimensions

TO-251B PACKAGE OUTLINE DIMENSIONS

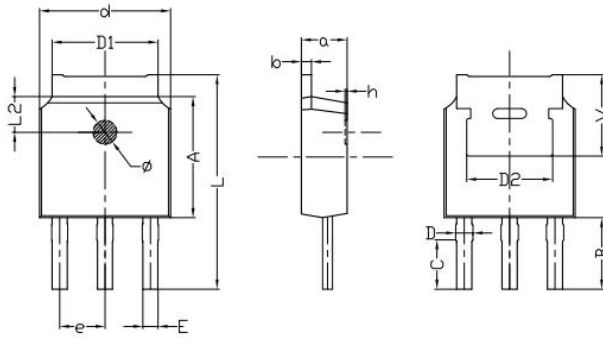

| Symbol | Dimensions In Millimeters | | Dimensions In Inches | |
|--------|---------------------------|-------|----------------------|--------|
| | min. | max. | min. | max. |
| a | 2.20 | 2.40 | 0.087 | 0.0946 |
| b | 0.46 | 0.58 | 0.018 | 0.023 |
| C | 2.45 | 2.65 | 0.097 | 0.104 |
| D | 0.80 | 0.90 | 0.032 | 0.035 |
| d | 6.30 | 6.70 | 0.248 | 0.264 |
| D1 | 5.00 | 5.50 | 0.197 | 0.217 |
| D2 | TYP 4.83 | | TYP 0.190 | |
| A | 5.80 | 6.20 | 0.228 | 0.244 |
| e | 2.19 | 2.39 | 0.086 | 0.094 |
| L | 10.40 | 11.00 | 0.4098 | 0.4334 |
| B | 3.50 | 3.70 | 0.1379 | 0.1458 |
| L2 | 1.5 | 1.8 | 0.059 | 0.071 |
| Φ | 1.10 | 1.30 | 0.0433 | 0.0512 |
| h | 0.00 | 0.30 | 0.000 | 0.012 |
| V | 5.25 | 5.85 | 0.207 | 0.230 |
| E | 0.60 | 0.80 | 0.0236 | 0.0315 |

TO-252B PACKAGE OUTLINE DIMENSIONS

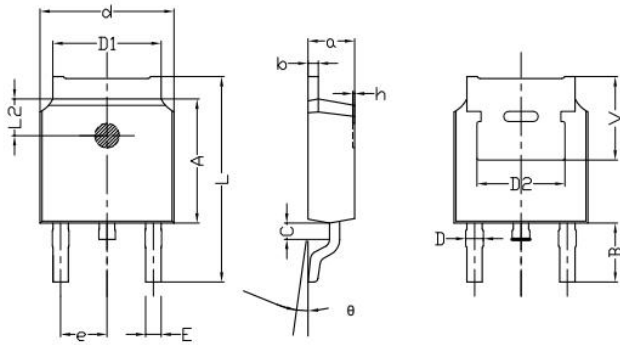

| Symbol | Dimensions In Millimeters | | Dimensions In Inches | |
|--------|---------------------------|-------|----------------------|-------|
| | min. | max. | min. | max. |
| a | 2.20 | 2.40 | 0.087 | 0.095 |
| b | 0.46 | 0.58 | 0.018 | 0.023 |
| c | 0.70 | 0.90 | 0.028 | 0.035 |
| D | 0.80 | 1.00 | 0.032 | 0.039 |
| d | 6.30 | 6.70 | 0.248 | 0.264 |
| D1 | 5.00 | 5.50 | 0.197 | 0.217 |
| D2 | TYP 4.83 | | TYP 0.190 | |
| A | 5.80 | 6.20 | 0.228 | 0.244 |
| e | 2.19 | 2.39 | 0.086 | 0.094 |
| L | 9.40 | 10.40 | 0.370 | 0.409 |
| B | 2.6 | 3.2 | 0.102 | 0.126 |
| L2 | 1.5 | 1.8 | 0.059 | 0.071 |
| θ | 0 | 8 | 0 | 8 |
| h | 0 | 0.3 | 0 | 0.012 |
| V | 5.25 | 5.85 | 0.207 | 0.230 |
| E | 0.6 | 0.8 | 0.024 | 0.032 |

9 Dimensions(continues)

TO-220C PACKAGE OUTLINE DIMENSIONS

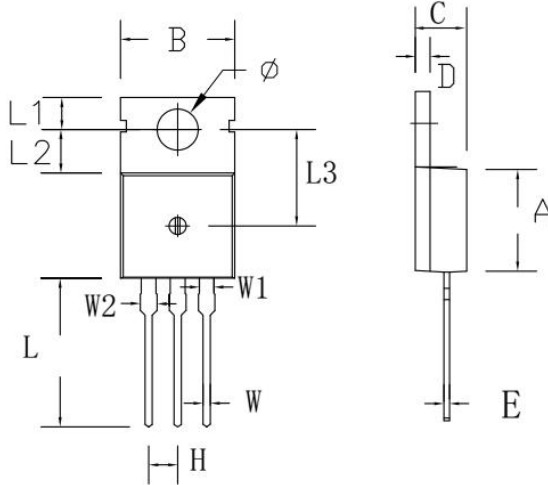

| Symbol | Dimensions In Millimeters | | Dimensions In Inches | |
|--------|---------------------------|-------|----------------------|-------|
| | min. | max. | min. | max. |
| A | 8.80 | 9.30 | 0.346 | 0.366 |
| B | 9.70 | 10.30 | 0.382 | 0.406 |
| C | 4.25 | 4.75 | 0.167 | 0.187 |
| D | 1.20 | 1.45 | 0.047 | 0.057 |
| E | 0.40 | 0.60 | 0.016 | 0.024 |
| H | 2.54 TYP | | 0.100 TYP | |
| W | 0.60 | 0.95 | 0.024 | 0.037 |
| W1 | 1.05 | 1.45 | 0.041 | 0.057 |
| W2 | 1.20 | 1.60 | 0.047 | 0.063 |
| L | 12.60 | 13.40 | 0.496 | 0.528 |
| L1 | 2.45 | 2.95 | 0.096 | 0.116 |
| L2 | 3.45 | 3.95 | 0.136 | 0.156 |
| L3 | 8.15 | 8.65 | 0.321 | 0.341 |
| Φ | 3.50 | 3.90 | 0.138 | 0.154 |

TO-220F PACKAGE OUTLINE DIMENSIONS

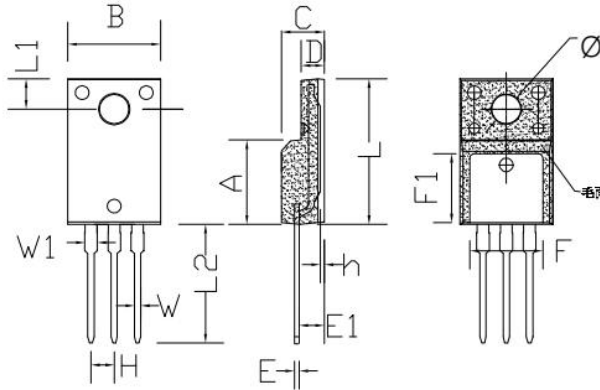

| Symbol | Dimensions In Millimeters | | Dimensions In Inches | |
|--------|---------------------------|-------|----------------------|-------|
| | min. | max. | min. | max. |
| A | 8.80 | 9.30 | 0.346 | 0.366 |
| B | 10.00 | 10.50 | 0.394 | 0.413 |
| C | 4.30 | 4.90 | 0.169 | 0.193 |
| D | 2.30 | 2.70 | 0.091 | 0.106 |
| L | 15.55 | 16.15 | 0.612 | 0.636 |
| h | 0.40 | 0.60 | 0.016 | 0.024 |
| L1 | 3.15 | 3.55 | 0.124 | 0.140 |
| L2 | 12.65 | 13.35 | 0.498 | 0.526 |
| W | 0.70 | 0.90 | 0.028 | 0.035 |
| W1 | 1.15 | 1.55 | 0.045 | 0.061 |
| H | 2.54 TYP | | 0.100 TYP | |
| E | 0.48 | 0.53 | 0.019 | 0.021 |
| Φ | 2.90 | 3.40 | 0.114 | 0.134 |
| E1 | 2.40 | 2.90 | 0.094 | 0.114 |
| F | 7.75 | 8.25 | 0.305 | 0.325 |
| F1 | 7.35 | 7.85 | 0.289 | 0.309 |

9 Dimensions(continues)

TO-262 PACKAGE OUTLINE DIMENSIONS

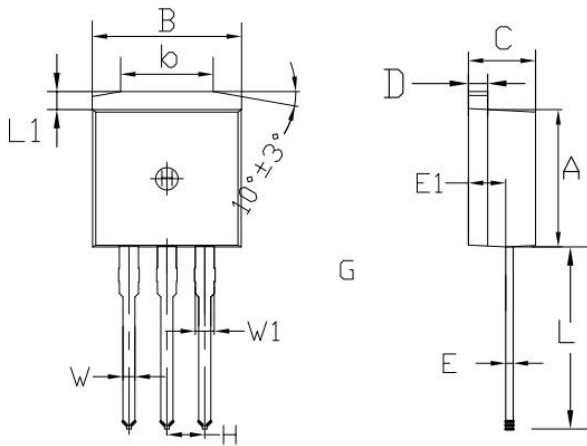

| Symbol | Dimensions In Millimeters | | Dimensions In Inches | |
|--------|---------------------------|-------|----------------------|--------|
| | min. | max. | min. | max. |
| A | 8.80 | 9.30 | 0.346 | 0.366 |
| B | 9.70 | 10.30 | 0.382 | 0.406 |
| C | 4.25 | 4.75 | 0.167 | 0.187 |
| D | 1.20 | 1.45 | 0.047 | 0.057 |
| E | 0.40 | 0.60 | 0.016 | 0.024 |
| L | 12.25 | 13.75 | 0.482 | 0.541 |
| L1 | 1.15 | 1.45 | 0.045 | 0.057 |
| E1 | 2.4 | 2.6 | 0.0945 | 0.1024 |
| W | 0.80 | 0.82 | 0.0315 | 0.034 |
| W1 | 1.20 | 1.30 | 0.047 | 0.051 |
| H | 2.54 TYP | | 0.200 TYP | |
| b | 5.50 | 6.50 | 0.216 | 0.256 |

TO-263 PACKAGE OUTLINE DIMENSIONS

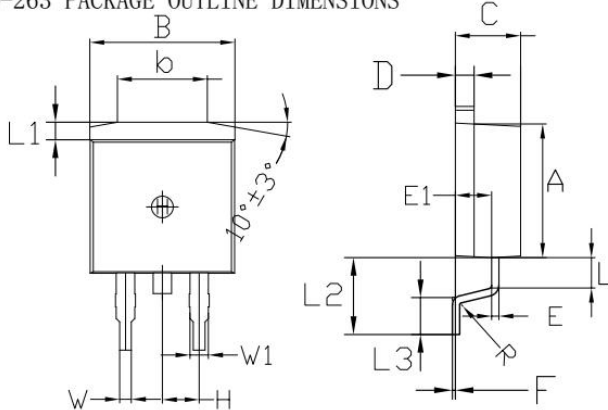

| Symbol | Dimensions In Millimeters | | Dimensions In Inches | |
|--------|---------------------------|-------|----------------------|--------|
| | min. | max. | min. | max. |
| A | 8.80 | 9.30 | 0.346 | 0.366 |
| B | 9.70 | 10.30 | 0.382 | 0.406 |
| C | 4.25 | 4.75 | 0.167 | 0.187 |
| D | 1.20 | 1.45 | 0.047 | 0.057 |
| E | 0.40 | 0.60 | 0.016 | 0.024 |
| L | 1.90 | 2.30 | 0.075 | 0.091 |
| L1 | 1.15 | 1.45 | 0.045 | 0.057 |
| R | 0.24 | 0.26 | 0.0095 | 0.0102 |
| W | 0.80 | 0.82 | 0.0315 | 0.0323 |
| W1 | 1.20 | 1.30 | 0.047 | 0.051 |
| H | 2.54 TYP | | 0.200 TYP | |
| b | 5.50 | 6.50 | 0.216 | 0.256 |
| E1 | 2.4 | 2.6 | 0.0946 | 0.1024 |
| L2 | 5.20 | 5.80 | 0.205 | 0.228 |
| L3 | 2.20 | 3.20 | 0.087 | 0.126 |
| F | 0.03 | 0.23 | 0.0012 | 0.0091 |

10 Attentions

- Jiangsu Donghai Semiconductor Technology CO.,LTD. reserves the right to change the specification without prior notice! The customer should obtain the latest version of the information before making the order and verify that the information is complete and up to date.
- It is the responsibility of the purchaser for any failure or failure of any semiconductor product under certain conditions. It is the responsibility of the purchaser to comply with safety standards and to take safety measures in the system design and machine manufacturing of Donghai products in order to avoid potential risk of failure. Injury or property damage.
- Product promotion is endless, our company will be dedicated to provide customers with better products.

11 Appendix

Revision history:

| Date | REV. | Description | Page |
|------------|------|-------------|------|
| 2017.05.14 | 1.0 | Original | |