

120A 100V N-channel Enhancement Mode Power MOSFET

1 Description

These N-channel enhancement mode power mosfets used advanced splite gate technology design, provided excellent Rdson and low gate charge. Which accords with the RoHS standard.

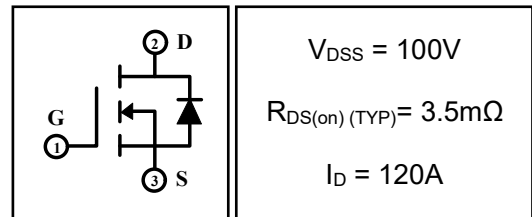

2 Features

- Fast switching
- Low on resistance
- Low gate charge
- High avalanche current
- Low reverse transfer capacitances
- 100% single pulse avalanche energy test
- 100% ΔV_{DS} test

3 Applications

- Switching power supply
- Inverter power management system
- Power tool control
- Automotive electronics applications

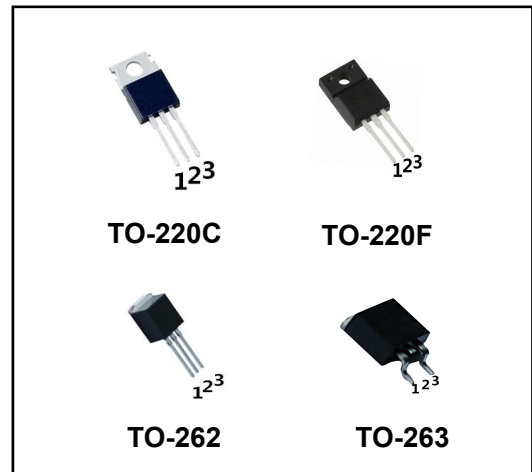

4 Electrical Characteristics

4.1 Absolute Maximum Ratings (Tc=25°C, unless otherwise noted)

Parameter	Symbol	Rating		Units	
		DH10H035R/ DHI10H035R/DHE10H035R	DHF10H 035R		
Drain-to-Source Voltage	V_{DSS}	100		V	
Gate-to-Source Voltage	V_{GSS}	±20		V	
Continuous Drain Current	$T_C=25^\circ C$	I_D	120		A
	$T_C=100^\circ C$		86		A
Pulsed Drain Current ⁽¹⁾	I_{DM}	480		A	
Single Pulse Avalanche Energy ⁽⁴⁾	E_{AS}	300		mJ	
Power Dissipation	$T_a=25^\circ C$	P_{tot}	2	2	W
	$T_C=25^\circ C$	P_{tot}	227	90	W
Isolation Voltage	V_{ISO}	/	2500	V	
Junction Temperature Range	T_j	-55~150		°C	
Storage Temperature Range	T_{stg}	-55~150		°C	
Maximum Temperature for soldering	T_L	300		°C	

4.2 Thermal Characteristics

Parameter	Symbol	Rating		Unit
		DH10H035R/ DHI10H035R/DHE10H035R	DHF10H 035R	
Thermal Resistance, Junction to Case-sink	R_{thJC}	0.55	1.39	°C/W
Thermal Resistance, Junction to Ambient	R_{thJA}	62.5	62.5	°C/W

4.3 Electrical Characteristics (T_c=25°C, unless otherwise noted)

Parameter	Symbol	Test Condition	Value			Units
			Min	Typ	Max	
Off Characteristics						
Drain-to-Source Breakdown Voltage	BV _{DSS}	I _D =250μA, V _{GS} =0V	100	115	—	V
Drain-to-Source Leakage Current	I _{DSS}	V _{DS} =100V, V _{GS} =0V, T _C =25°C	—	—	1	μA
		V _{DS} =80V, V _{GS} =0V, T _C =125°C	—	—	100	μA
Gate-to-Source Leakage Current	I _{GSS}	V _{GS} =±20V, V _{DS} =0V	—	—	±100	nA
On Characteristics						
Gate Threshold Voltage	V _{GS(th)}	V _{DS} =V _{GS} , I _D =250μA	2	3	4	V
Drain-to-Source on-state Resistance	R _{DS(on)}	V _{GS} =10V, I _D =50A	—	3.5	4.0	mΩ
Forward Transfer Conductance	g _{fs}	V _{DS} =5V, I _D =50A	—	108	—	S
Dynamic Characteristics						
Input Capacitance	C _{iss}	V _{GS} =0V, V _{DS} =50V, f=1.0MHz	—	6920	—	pF
Output Capacitance	C _{oss}		—	1026	—	
Reverse Transfer Capacitance	C _{rss}		—	33.4	—	
Gate Resisitance	R _G	V _{DD} =0V, V _{GS} =0V, F=1MHz	—	2.6	—	Ω
Switching Characteristics						
Turn-on Delay Time	t _{d(on)}	V _{DS} =50V, V _{GS} =10V, R _{GEN} =3Ω	—	48	—	nS
Turn-on Rise Time	t _r		—	56	—	
Turn-off Delay Time	t _{d(off)}		—	75	—	
Turn-off Fall Time	t _f		—	33	—	
Total Gate Charge	Q _g	I _D =50A, V _{DD} =50V, V _{GS} =10V	—	117	—	nC
Gate-to-Source Charge	Q _{gs}		—	40	—	
Gate-to-Drain("Miller") Charge	Q _{gd}		—	37	—	
Drain-Source Diode Characteristics						
Diode Forward Voltage ⁽³⁾	V _{SD}	V _{GS} =0V, I _S =50A	—	0.85	1.3	V
Diode Forward Current	I _S		—	—	120	A
Reverse Recovery Time ⁽³⁾	t _{rr}	T _J =25°C, I _F =20A, dI _F /dt=500A/μS, V _{GS} =0V	—	60	—	nS
Reverse Recovery Charge ⁽³⁾	Q _{rr}		—	560	—	nC

Notes:

- 1: Repetitive rating, pulse width limited by maximum junction temperature.
- 2: Surface mounted on FR4 Board, t≤10sec.
- 3: Pulse width ≤ 300μs, duty cycle ≤ 2%.
- 4: L=0.5mH, I_D=35A, V_{DD}=50V, V_{GATE}=100V, Start T_J=25°C.

5 Typical characteristics diagrams

Fig 1: Output Characteristics

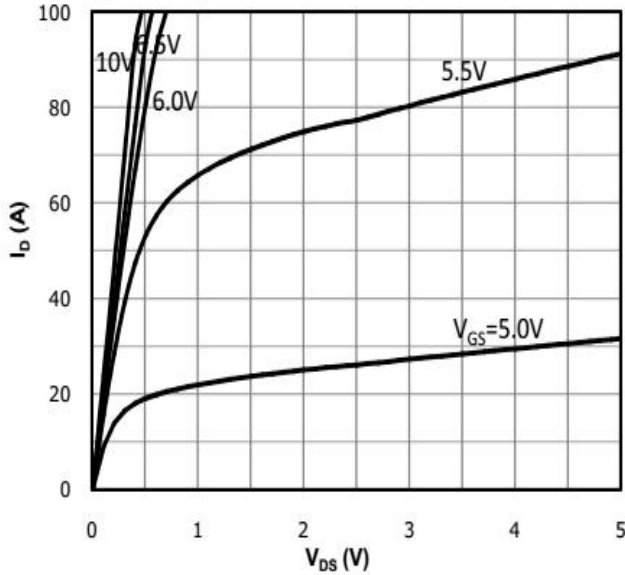

Fig 2: Transfer Characteristics

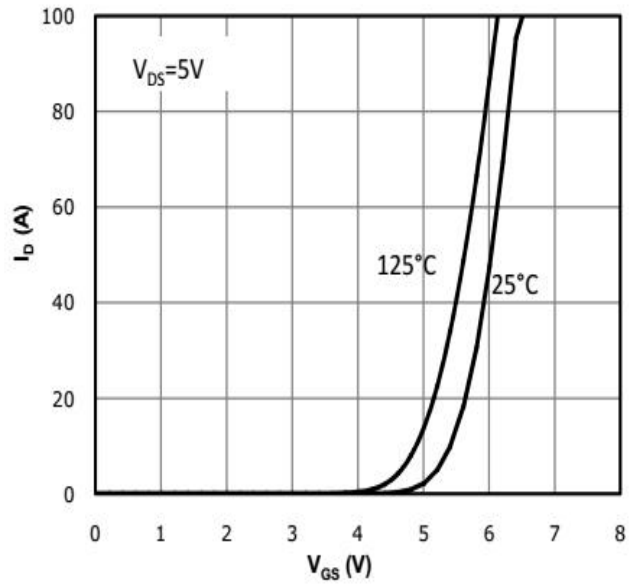

Fig 3: $R_{DS(on)}$ vs Drain Current and Gate Voltage

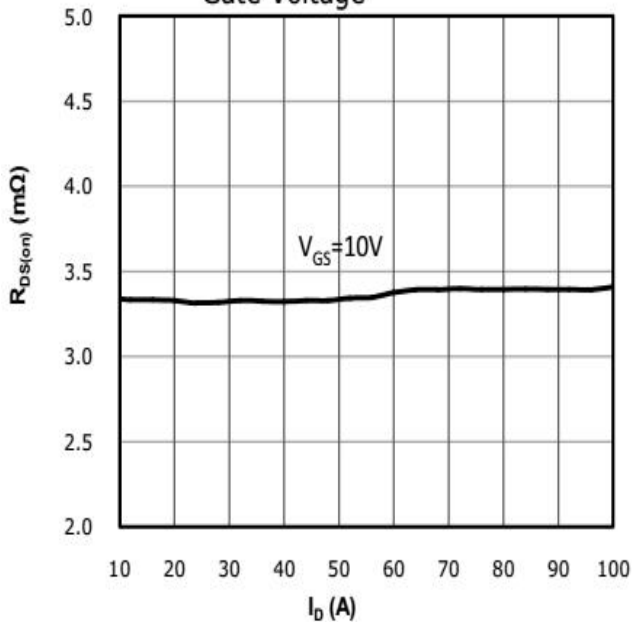
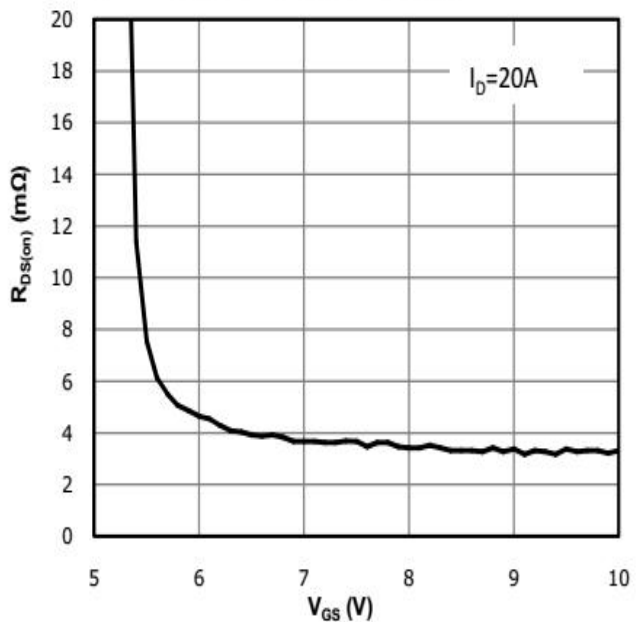

Fig 4: $R_{DS(on)}$ vs Gate Voltage



5 Typical characteristics diagrams(continues)

Fig 5: Rds(on) vs. Temperature

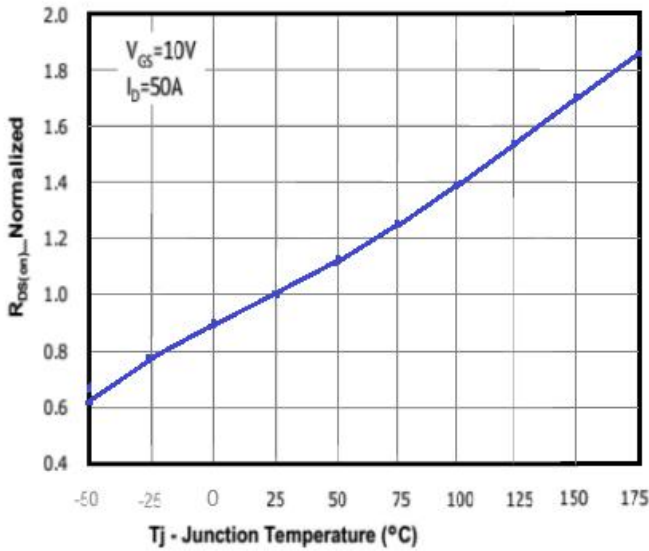

Fig 6: Capacitance Characteristics

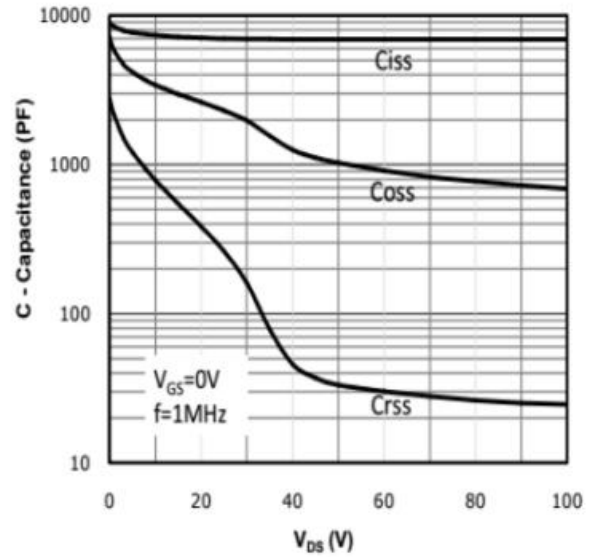

Fig 7: Gate Charge Characteristics

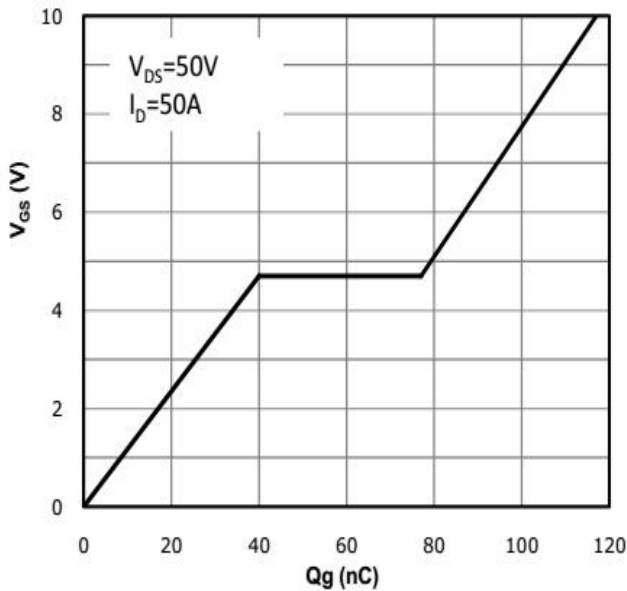
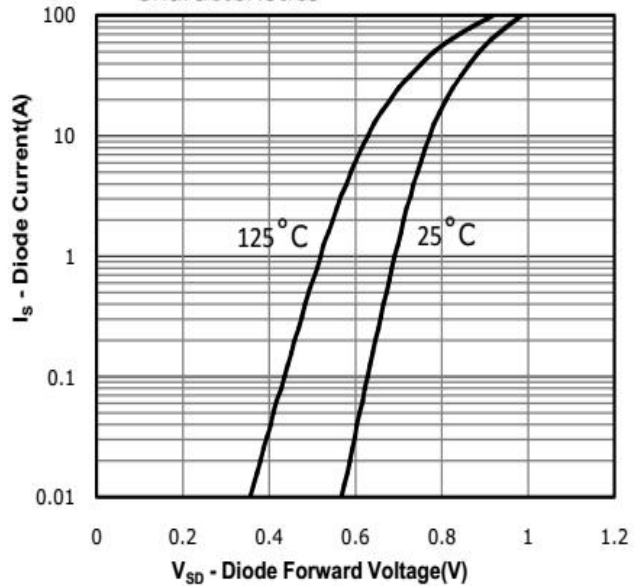

Fig 8: Body-diode Forward Characteristics



5 Typical characteristics diagrams(continues)

Fig 9: Power Dissipation

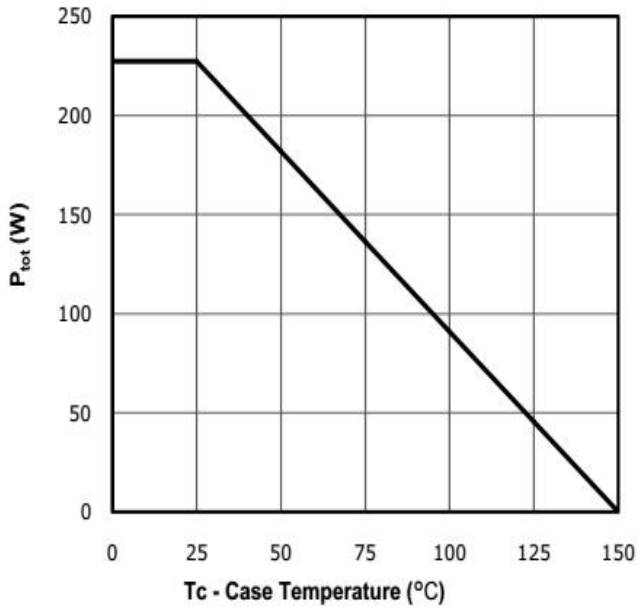

Fig 10: Drain Current Derating

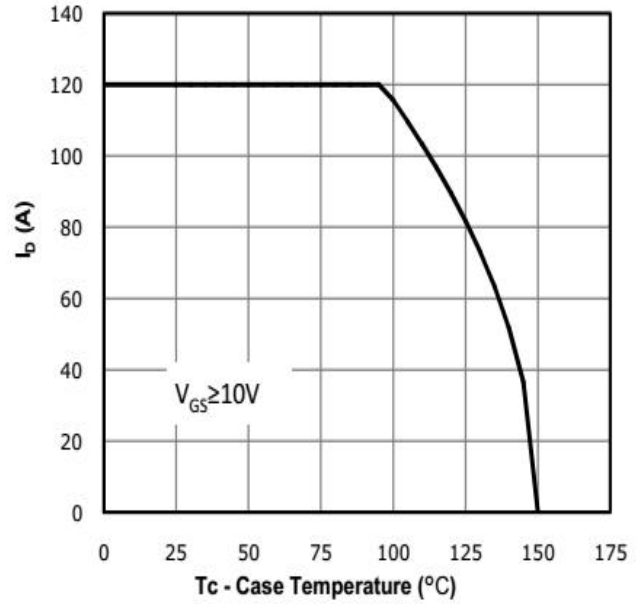
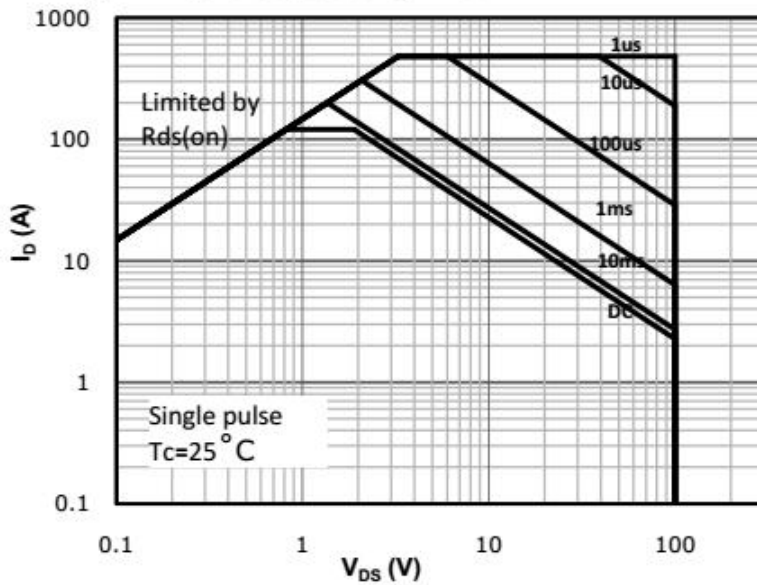
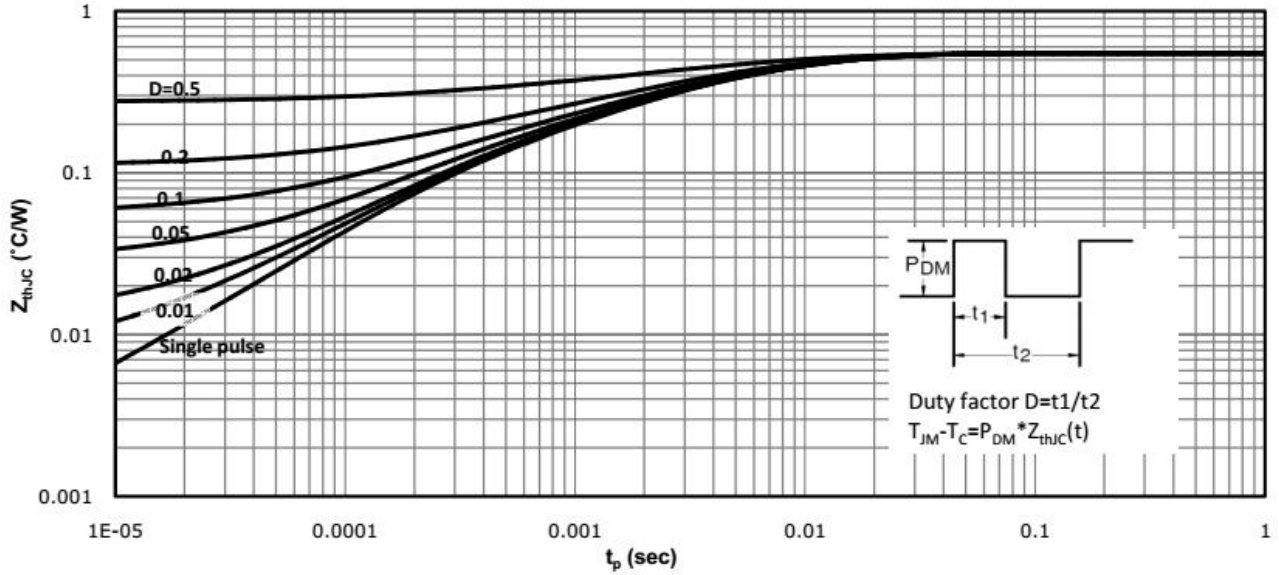

Fig 11: Safe Operating Area



5 Typical characteristics diagrams(continues)

Fig 12: Max. Transient Thermal Impedance



6 Typical Test Circuit and Waveform

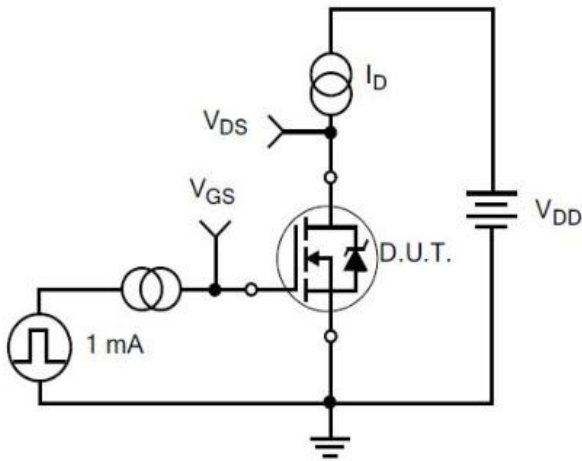

1) Gate Charge Test Circuit

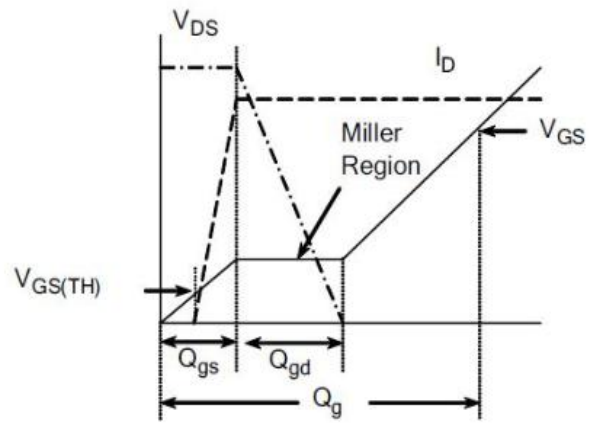

2) Gate Charge Waveform

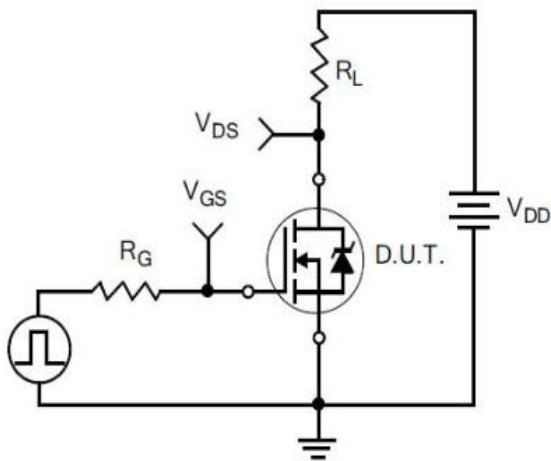

3) Resistive Switching Test Circuit

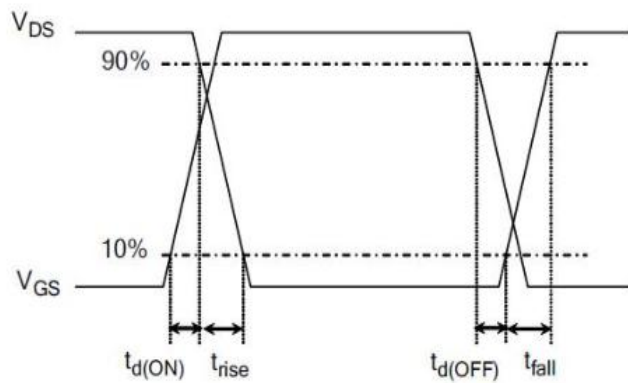

4) Resistive Switching Waveforms

6 Typical Test Circuit and Waveform(continues)

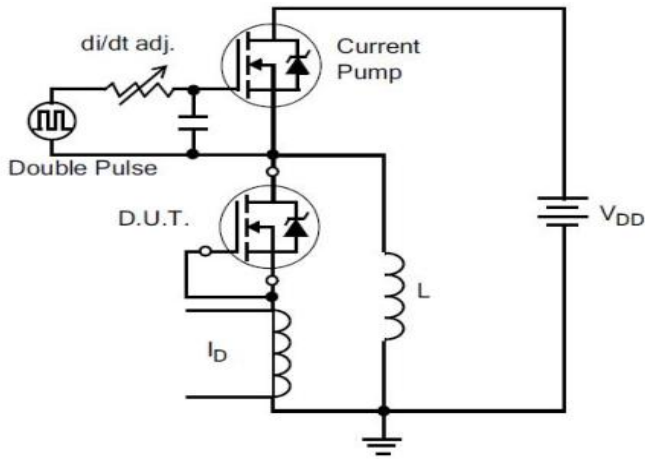

5) Diode Reverse Recovery Test Circuit

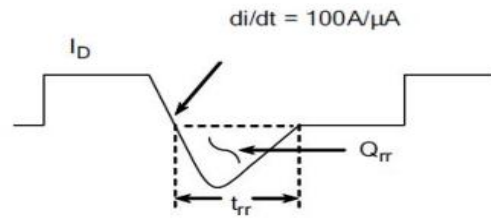

6) Diode Reverse Recovery Waveform

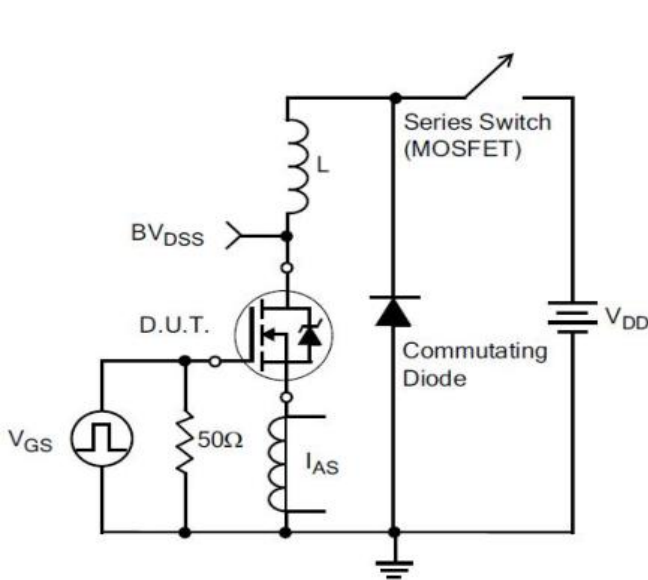

7) . Unclamped Inductive Switching Test Circuit

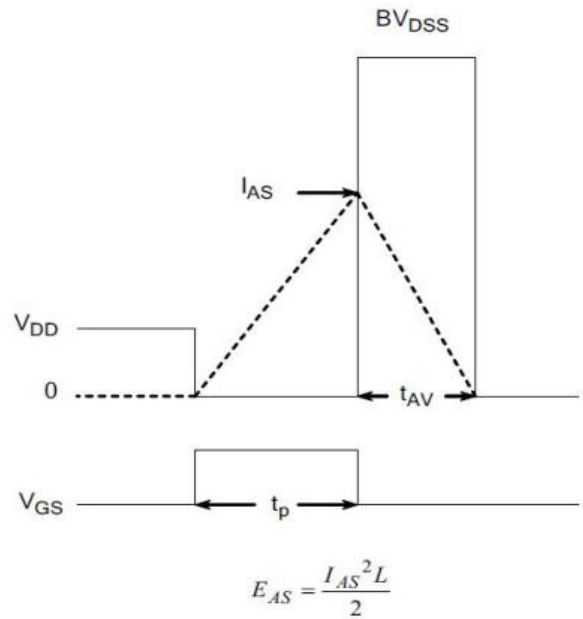

8) Unclamped Inductive Switching Waveforms

7 Product Names Rules

D H F X X N E X X X R

LOGO Code: DH

Packaging Code
220F: F 220: Nothing
251: B 252: D
262: I 263: E

Rated Voltage Code
With 2-3 Digitals,
For Example:
90 on behalf of 90V
10H on behalf of 100V

Channel Polarity Code
N on behalf of N channel
P on behalf of P channel

RDSON Number Code: R

RDSON Specification Code
With 3 Digitals, For Example:
045 on behalf of 4.5mΩ
050 on behalf of 5.0mΩ

Special Function Code
E on behalf of build-in ESD
Nothing on behalf of not ESD

8 Product Specifications and Packaging Models

Product Model	Package Type	Mark Name	RoHS	Package	Quantity
DH10H035R	TO-220	DH10H035R	Pb-free	Tube	1000/box
DHF10H035R	TO-220F	DHF10H035R	Pb-free	Tube	1000/box
DHI10H035R	TO-262	DHI10H035R	Pb-free	Tube	1000/box
DHE10H035R	TO-263	DHE10H035R	Pb-free	Tape & Reel	800/box

9 Dimensions

TO-220C PACKAGE OUTLINE DIMENSIONS

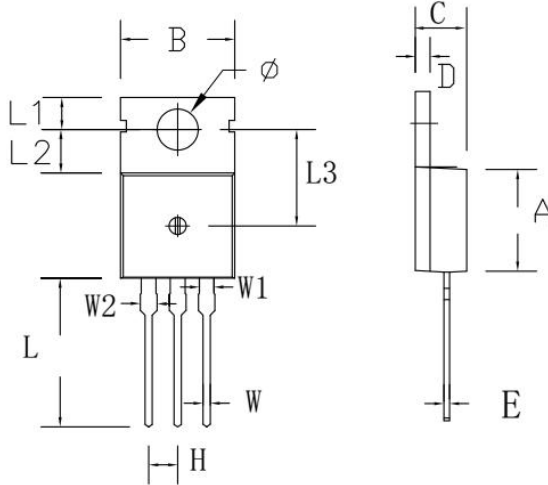

Symbol	Dimensions In Millimeters		Dimensions In Inches	
	min.	max.	min.	max.
A	8.80	9.30	0.346	0.366
B	9.70	10.30	0.382	0.406
C	4.25	4.75	0.167	0.187
D	1.20	1.45	0.047	0.057
E	0.40	0.60	0.016	0.024
H	2.54 TYP		0.100 TYP	
W	0.60	0.95	0.024	0.037
W1	1.05	1.45	0.041	0.057
W2	1.20	1.60	0.047	0.063
L	12.60	13.40	0.496	0.528
L1	2.45	2.95	0.096	0.116
L2	3.45	3.95	0.136	0.156
L3	8.15	8.65	0.321	0.341
Φ	3.50	3.90	0.138	0.154

TO-220F PACKAGE OUTLINE DIMENSIONS

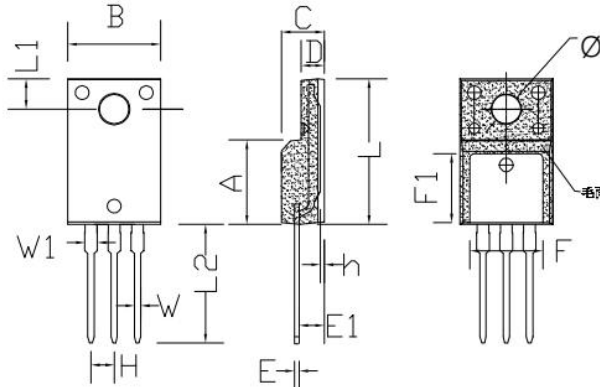

Symbol	Dimensions In Millimeters		Dimensions In Inches	
	min.	max.	min.	max.
A	8.80	9.30	0.346	0.366
B	10.00	10.50	0.394	0.413
C	4.30	4.90	0.169	0.193
D	2.30	2.70	0.091	0.106
L	15.55	16.15	0.612	0.636
h	0.40	0.60	0.016	0.024
L1	3.15	3.55	0.124	0.140
L2	12.65	13.35	0.498	0.526
W	0.70	0.90	0.028	0.035
W1	1.15	1.55	0.045	0.061
H	2.54 TYP		0.100 TYP	
E	0.48	0.53	0.019	0.021
Φ	2.90	3.40	0.114	0.134
E1	2.40	2.90	0.094	0.114
F	7.75	8.25	0.305	0.325
F1	7.35	7.85	0.289	0.309

9 Dimensions(continues)

TO-262 PACKAGE OUTLINE DIMENSIONS

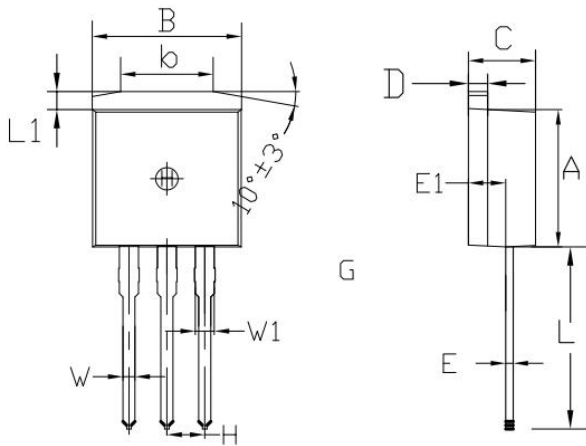

Symbol	Dimensions In Millimeters		Dimensions In Inches	
	min.	max.	min.	max.
A	8.80	9.30	0.346	0.366
B	9.70	10.30	0.382	0.406
C	4.25	4.75	0.167	0.187
D	1.20	1.45	0.047	0.057
E	0.40	0.60	0.016	0.024
L	12.25	13.75	0.482	0.541
L1	1.15	1.45	0.045	0.057
E1	2.4	2.6	0.0945	0.1024
W	0.80	0.82	0.0315	0.034
W1	1.20	1.30	0.047	0.051
H	2.54 TYP		0.200 TYP	
b	5.50	6.50	0.216	0.256

TO-263 PACKAGE OUTLINE DIMENSIONS

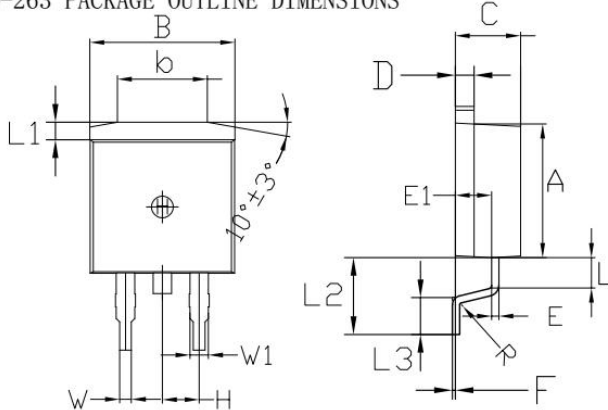

Symbol	Dimensions In Millimeters		Dimensions In Inches	
	min.	max.	min.	max.
A	8.80	9.30	0.346	0.366
B	9.70	10.30	0.382	0.406
C	4.25	4.75	0.167	0.187
D	1.20	1.45	0.047	0.057
E	0.40	0.60	0.016	0.024
L	1.90	2.30	0.075	0.091
L1	1.15	1.45	0.045	0.057
R	0.24	0.26	0.0095	0.0102
W	0.80	0.82	0.0315	0.0323
W1	1.20	1.30	0.047	0.051
H	2.54 TYP		0.200 TYP	
b	5.50	6.50	0.216	0.256
E1	2.4	2.6	0.0946	0.1024
L2	5.20	5.80	0.205	0.228
L3	2.20	3.20	0.087	0.126
F	0.03	0.23	0.0012	0.0091

10 Attentions

- Jiangsu Donghai Semiconductor Technology CO.,LTD. reserves the right to change the specification without prior notice! The customer should obtain the latest version of the information before making the order and verify that the information is complete and up to date.
- It is the responsibility of the purchaser for any failure or failure of any semiconductor product under certain conditions. It is the responsibility of the purchaser to comply with safety standards and to take safety measures in the system design and machine manufacturing of Donghai products in order to avoid potential risk of failure. Injury or property damage.
- Product promotion is endless, our company will be dedicated to provide customers with better products.

11 Appendix

Revision history:

Date	REV.	Description	Page
2017.03.09	1.0	Original	