

180A 60V N-channel Enhancement Mode Power MOSFET

1 Description

The N-channel enhancement mode power mosfets used advanced splite gate trench technology design, provided excellent Rdson and low gate charge. Which accords with the RoHS standard.

2 Features

- Fast switching
- Low on resistance
- Low gate charge
- Low reverse transfer capacitances
- 100% single pulse avalanche energy test
- 100% ΔV_{DS} test

3 Applications

- Power switching applications
- DC-DC converters
- Full bridge control

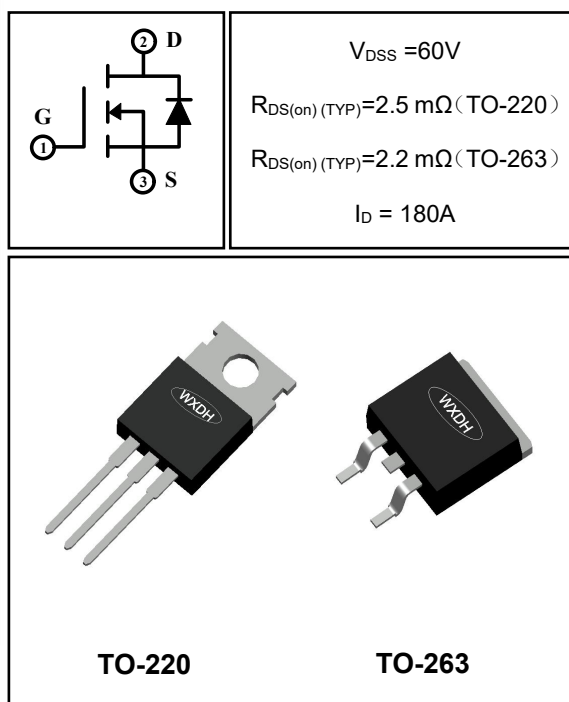

4 Electrical Characteristics

4.1 Absolute Maximum Ratings (T_c=25°C, unless otherwise noted)

Parameter	Symbol	Rating	Units
Drian-to-Source Voltage	V _{DSS}	60	V
Gate-to-Source Voltage	V _{GSS}	±20	V
Continuous Drain Current	I _D	T _C =25°C	180
		T _C =100°C	128
Pulsed Drain Current ⁽¹⁾	I _{DM}	720	A
Single Pulse Avalanche Energy ⁽⁴⁾	E _{AS}	1045	mJ
Avalanche Current ⁽⁴⁾	I _{AS}	65	A
Power Dissipation	P _{tot}	T _a =25°C	1.9
		T _C =25°C	179
Junction Temperature Range	T _j	-55~150	°C
Storage Temperature Range	T _{stg}	-55~150	°C

4.2 Thermal Characteristics

Parameter	Symbol	Rating		Units
		Typ	Max	
Thermal Resistance, Junction to Case-sink	R _{thJC}	0.54	0.7	°C/W
Thermal Resistance, Junction to Ambient	R _{thJA}	50	65	°C/W

4.3 Electrical Characteristics (Tc=25°C, unless otherwise noted)

Parameter	Symbol	Test Condition	Value			Units
			Min	Typ	Max	
Off Characteristics						
Drain-to-Source Breakdown Voltage	BV _{DSS}	I _D =250μA, V _{GS} =0V	60	--	--	V
Drain-to-Source Leakage Current	I _{DSS}	V _{DS} =60V, V _{GS} =0V, T _C =25°C	--	--	1	μA
		V _{DS} =60V, V _{GS} =0V, T _C =125°C	--	--	100	μA
Gate-to-Source Leakage Current	I _{GSS}	V _{GS} =±20V, V _{DS} =0V	--	--	±100	nA
On Characteristics						
Gate Threshold Voltage	V _{GS(th)}	V _{DS} =V _{GS} , I _D =250μA	2.0	3.0	4.0	V
Drain-to-Source on-state Resistance	R _{DS(on)} (TO-220)	V _{GS} =10V, I _D =90A	--	2.5	2.9	mΩ
	R _{DS(on)} (TO-263)		--	2.2	2.6	mΩ
Dynamic Characteristics						
Input Capacitance	C _{ISS}	V _{GS} =0V, V _{DS} =30V, f=1.0MHz	--	4553	--	pF
Output Capacitance	C _{OSS}		--	1283	--	
Reverse Transfer Capacitance	C _{RSS}		--	68	--	
Gate Resisitance	R _G	V _{DD} =0V, V _{GS} =0V, F=1MHz	--	1.8	--	Ω
Switching Characteristics						
Turn-on Delay Time	t _{d(on)}	I _D =90A, V _{DD} =30V, V _{GS} =10V, R _{GEN} =1.6Ω	--	17.6	--	nS
Turn-on Rise Time	t _r		--	102.3	--	
Turn-off Delay Time	t _{d(off)}		--	33.0	--	
Turn-off Fall Time	t _f		--	106.9	--	
Total Gate Charge	Q _g	I _D =90A, V _{DD} =30V, V _{GS} =10V	--	61.0	--	nC
Gate-to-Source Charge	Q _{gs}		--	25.5	--	
Gate-to-Drain("Miller") Charge	Q _{gd}		--	12.9	--	
Drain-Source Diode Characteristics						
Diode Forward Voltage ⁽³⁾	V _{SD}	V _{GS} =0V, I _S =95A	--	--	1.2	V
Diode Forward Current	I _S		--	--	180	A
Reverse Recovery Time ⁽³⁾	t _{rr}	T _J =25°C, I _F =60A dI _F /dt=110A/μS, V _{GS} =0V	--	42.4	--	nS
Reverse Recovery Charge ⁽³⁾	Q _{rr}		--	29.7	--	nC

Notes:

- 1: Repetitive rating, pulse width limited by maximum junction temperature.
- 2: Surface mounted on FR4 Board, t_s≤10sec.
- 3: Pulse width ≤ 300μs, duty cycle ≤ 2%.
- 4: L=0.5mH, I_D=65A, V_{DD}=50V, R_G=25Ω, V_{GATE}=60V, Start T_J=25°C.

5 Typical characteristics diagrams

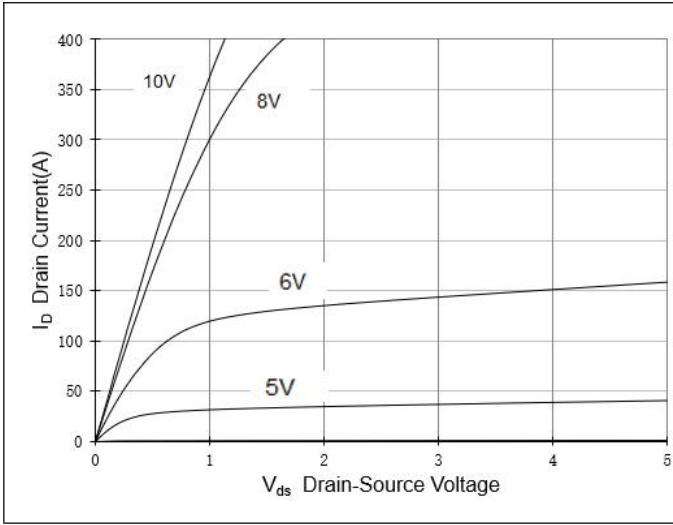

Figure 1 Output Characteristics

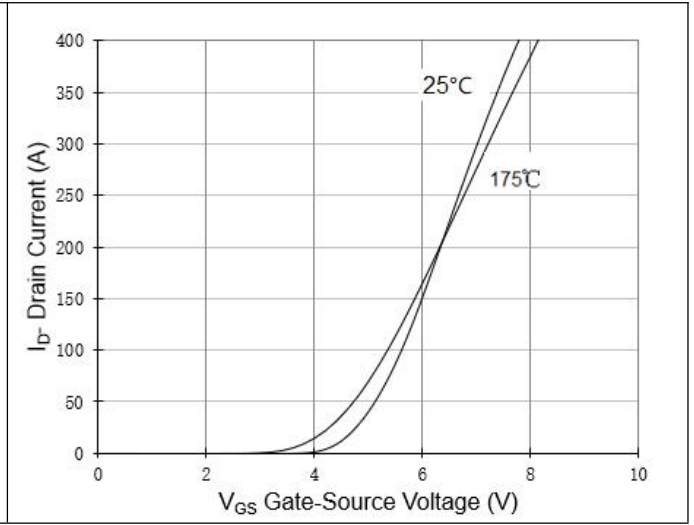

Figure 2 Transfer Characteristics

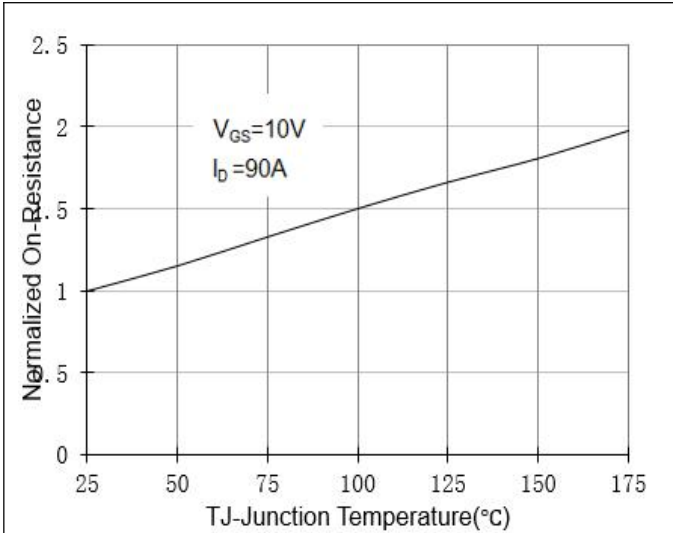

Figure 3 Rds(on)-Junction Temperature

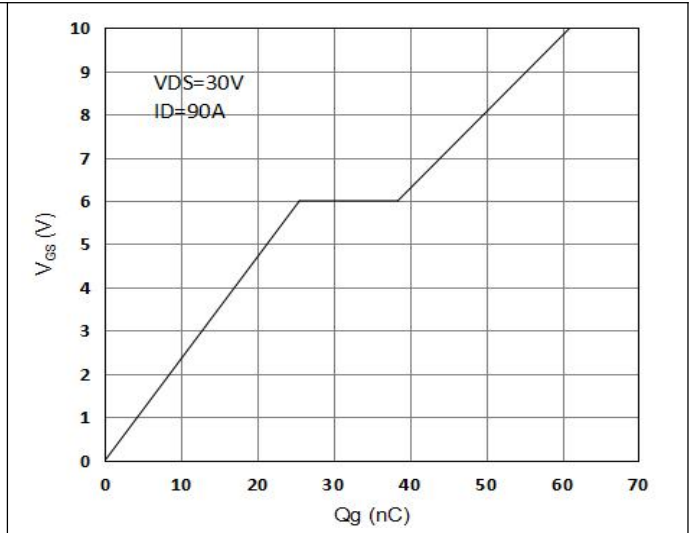

Figure 4 Gate Charge

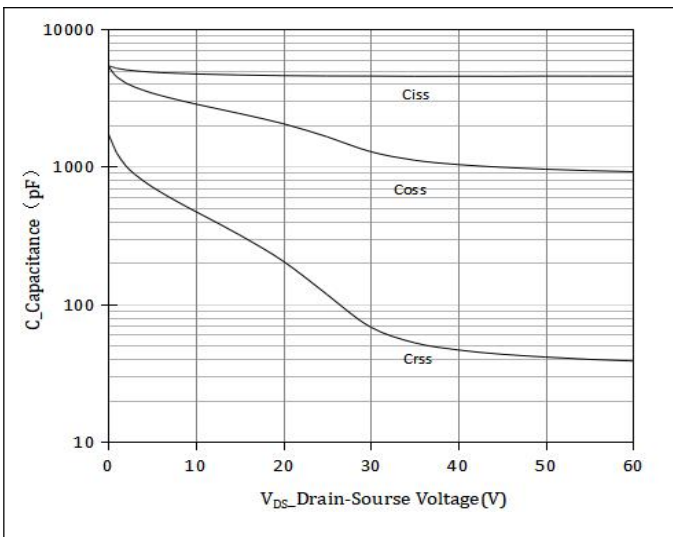

Figure 5 Capacitance vs Vds

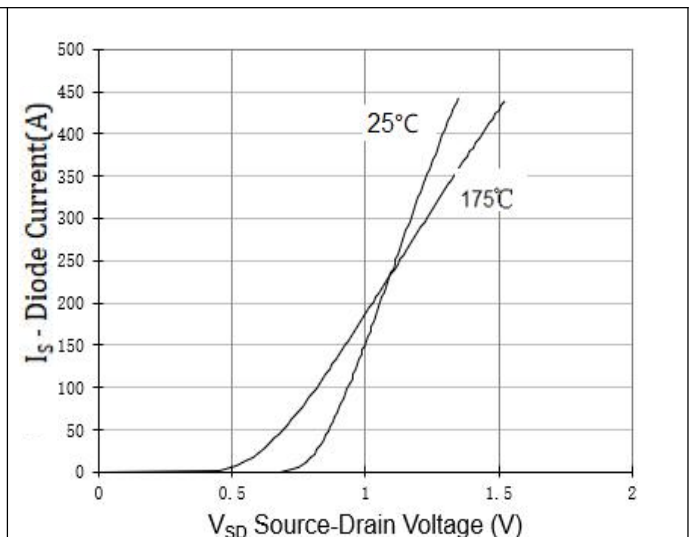

Figure 6 Source-Drain Diode Forward

5 Typical characteristics diagrams(continues)

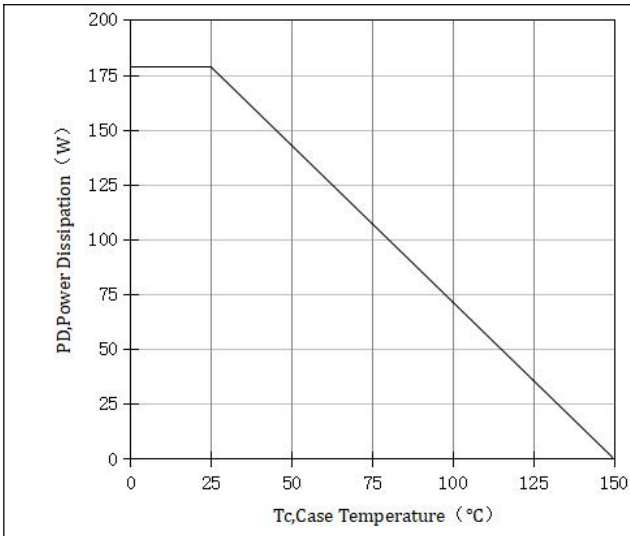

Figure 7 Power De-rating

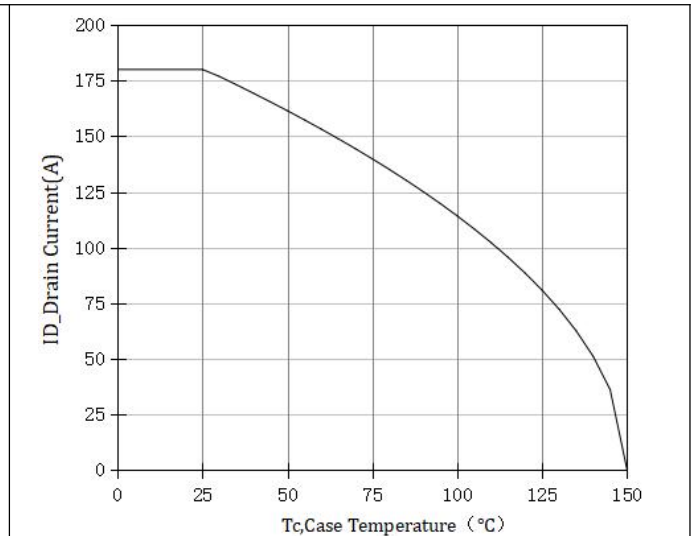

Figure 8 Current De-rating

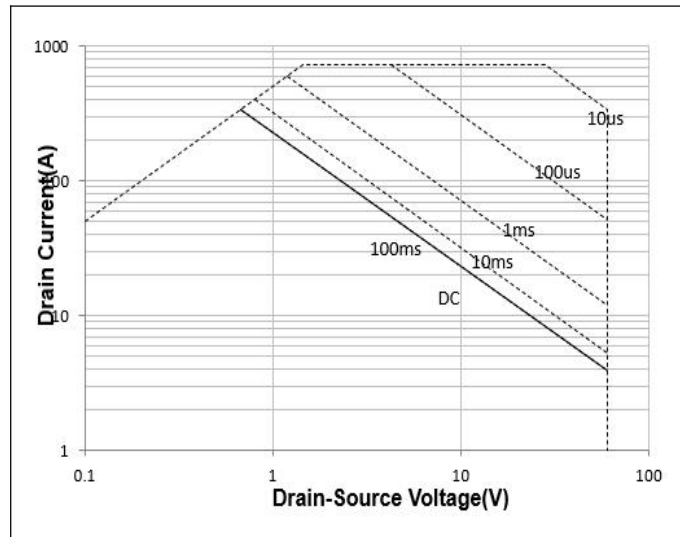

Figure 9 Safe Operation Area

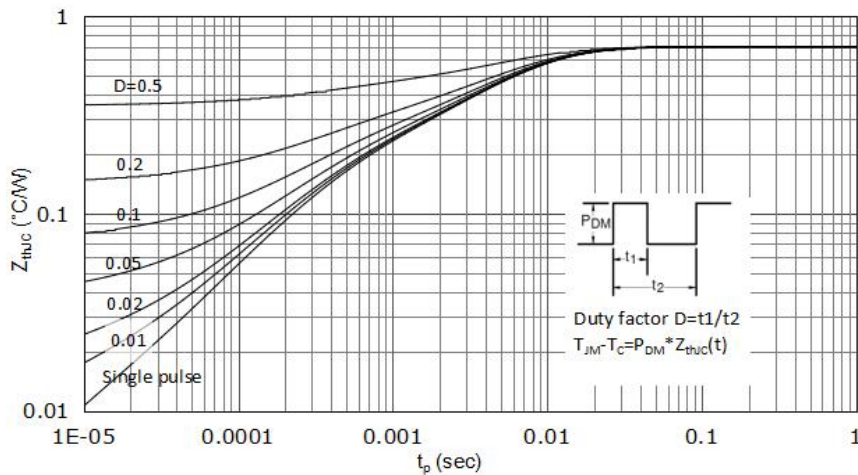
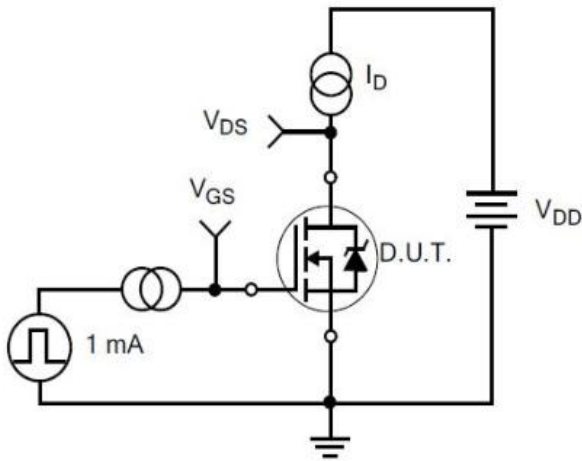
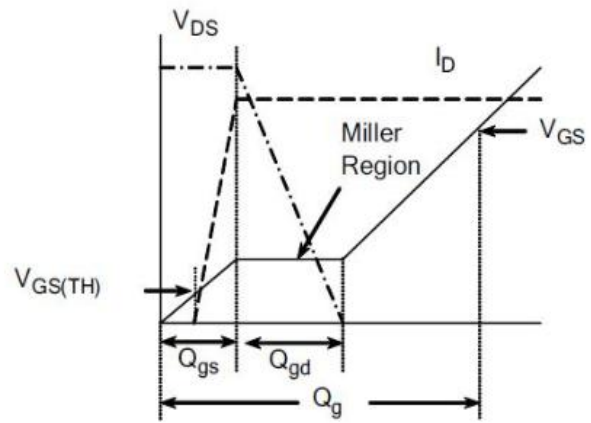

Figure 10 Normalized Maximum Transient Thermal Impedance

6 Typical Test Circuit and Waveform



1) Gate Charge Test Circuit



2) . Gate Charge Waveform

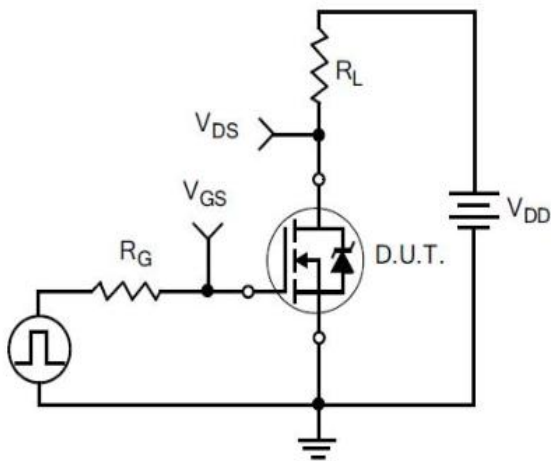

3) Resistive Switching Test Circuit

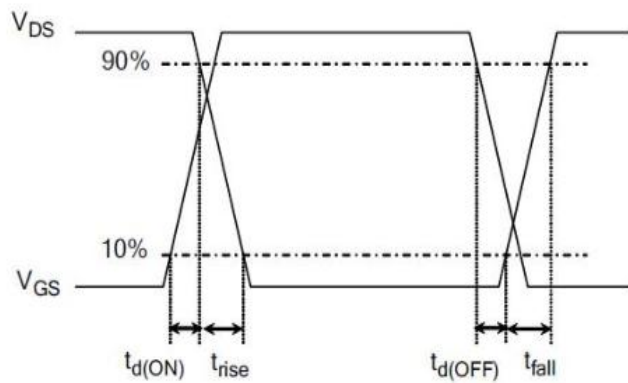

4) Resistive Switching Waveforms

6 Typical Test Circuit and Waveform(continues)

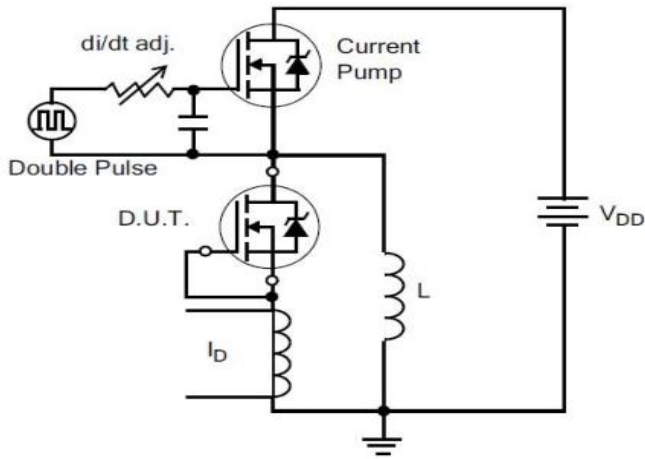

5) Diode Reverse Recovery Test Circuit

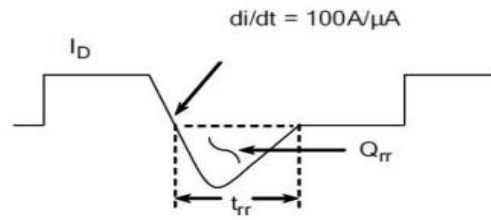

6) Diode Reverse Recovery Waveform

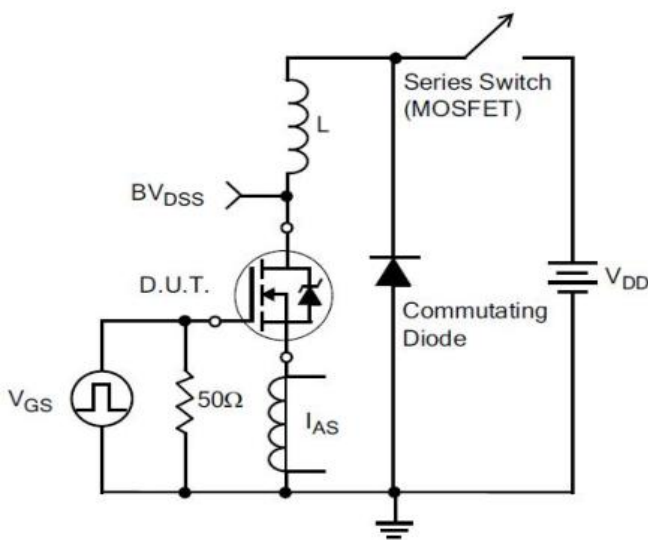

7) . Unclamped Inductive Switching Test Circuit

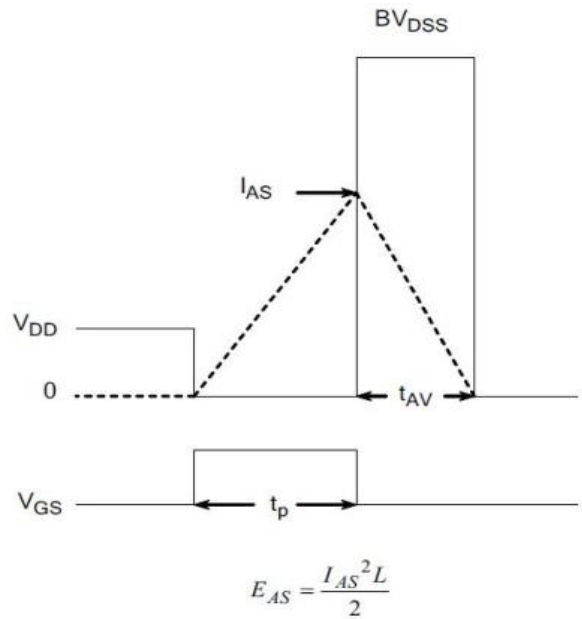

8) Unclamped Inductive Switching Waveforms

7 Product Names Rules

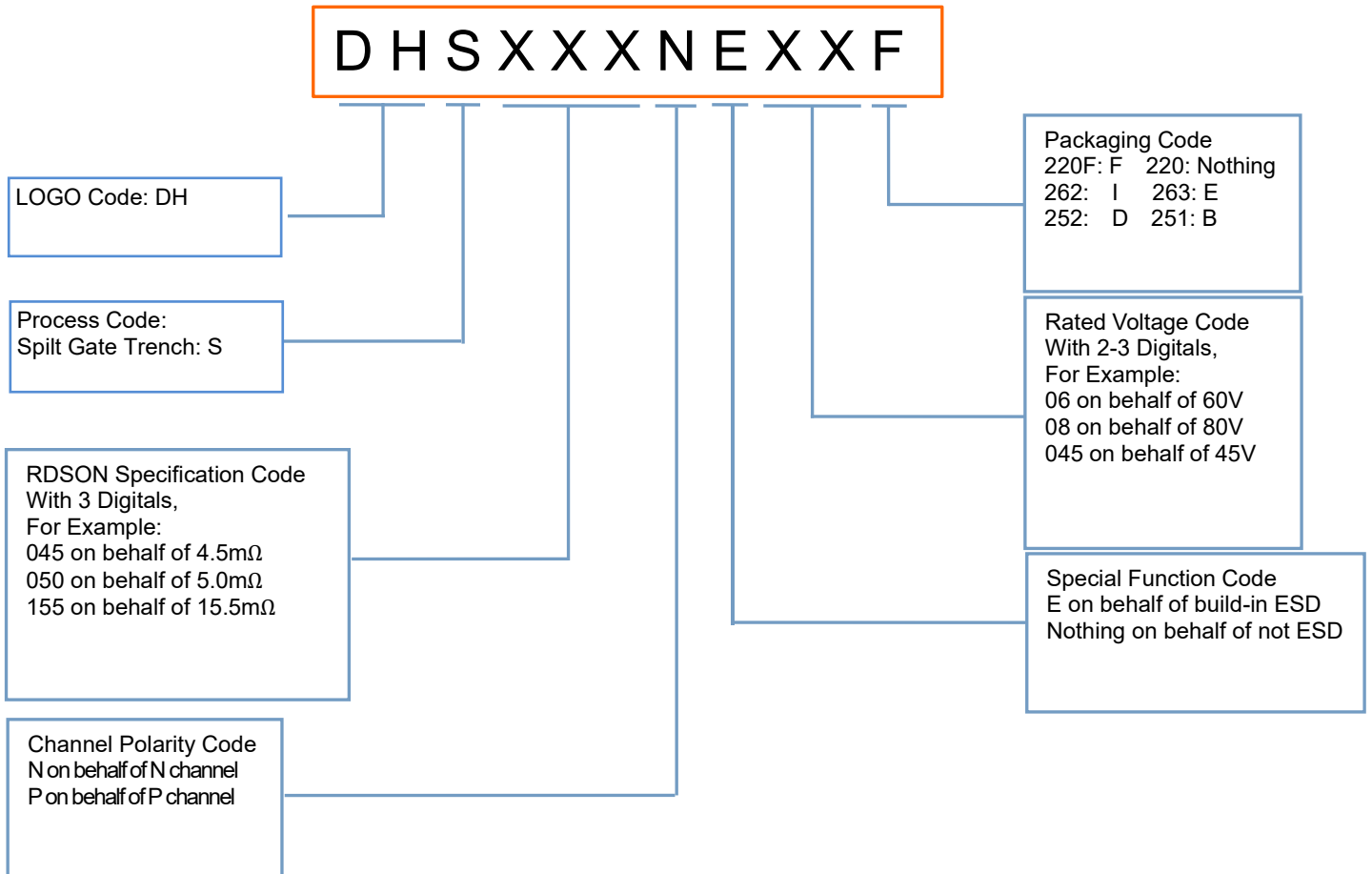

8 Product Specifications and Packaging Models

Product Model	Package Type	Mark Name	RoHS	Package	Quantity
DHS025N06	TO-220	DHS025N06	Pb-free	Tube	1000/box
DHS025N06E	TO-263	DHS025N06E	Pb-free	Tape & Reel	800/box

9 Dimensions

TO-220C PACKAGE OUTLINE DIMENSIONS

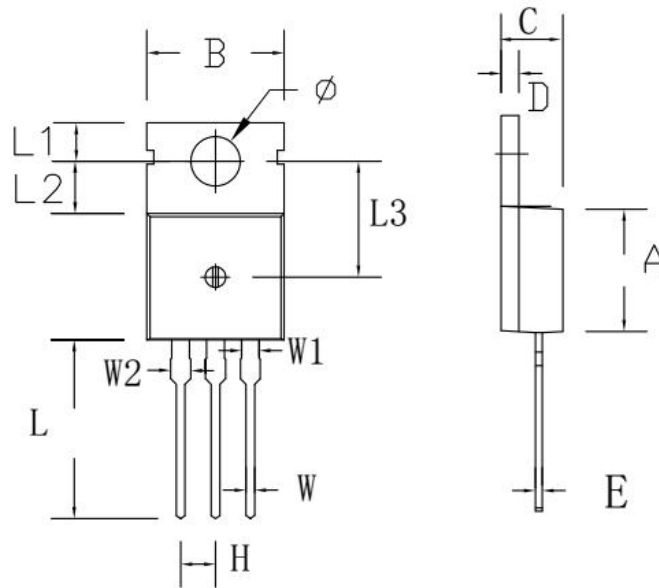

Symbol	Dimensions In Millimeters		Dimensions In Inches	
	min.	max.	min.	max.
A	8.80	9.30	0.346	0.366
B	9.70	10.30	0.382	0.406
C	4.25	4.75	0.167	0.187
D	1.20	1.45	0.047	0.057
E	0.40	0.60	0.016	0.024
H	2.54 TYP		0.100 TYP	
W	0.60	0.95	0.024	0.037
W1	1.05	1.45	0.041	0.057
W2	1.20	1.60	0.047	0.063
L	12.60	13.40	0.496	0.528
L1	2.45	2.95	0.096	0.116
L2	3.45	3.95	0.136	0.156
L3	8.15	8.65	0.321	0.341
Φ	3.50	3.90	0.138	0.154

9 Dimensions(continues)

TO-263 PACKAGE OUTLINE DIMENSIONS

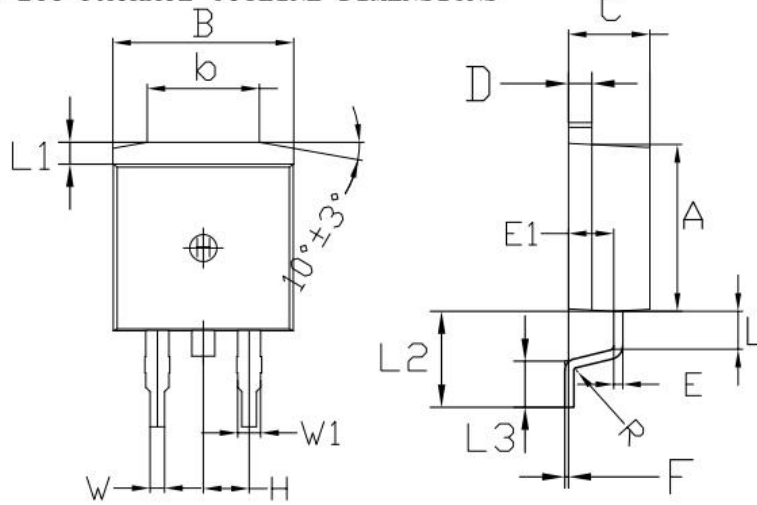

Symbol	Dimensions In Millimeters		Dimensions In Inches	
	min.	max.	min.	max.
A	8.80	9.30	0.346	0.366
B	9.70	10.30	0.382	0.406
C	4.25	4.75	0.167	0.187
D	1.20	1.45	0.047	0.057
E	0.40	0.60	0.016	0.024
L	1.90	2.30	0.075	0.091
L1	1.15	1.45	0.045	0.057
R	0.24	0.26	0.0095	0.0102
W	0.80	0.82	0.0315	0.0323
W1	1.20	1.30	0.047	0.051
H	2.54 TYP		0.200 TYP	
b	5.50	6.50	0.216	0.256
E1	2.4	2.6	0.0946	0.1024
L2	5.20	5.80	0.205	0.228
L3	2.20	3.20	0.087	0.126
F	0.03	0.23	0.0012	0.0091

10 Attentions

- Jiangsu Donghai Semiconductor Technology CO.,LTD. reserves the right to change the specification without prior notice! The customer should obtain the latest version of the information before making the order and verify that the information is complete and up to date.
- It is the responsibility of the purchaser for any failure or failure of any semiconductor product under certain conditions. It is the responsibility of the purchaser to comply with safety standards and to take safety measures in the system design and machine manufacturing of Donghai products in order to avoid potential risk of failure. Injury or property damage.
- Product promotion is endless, our company will be dedicated to provide customers with better products.

11 Appendix

Revision history:

Date	REV.	Description	Page
2021.04.04	1.0	Original	10
2023.7.12	2.0	Update	