

140A 150V N-channel Enhancement Mode Power MOSFET

1 Description

This N-channel enhancement mode power MOSFET utilizes advanced Split Gate Trench technology, which provides excellent $R_{DS(on)}$ and low Gate charge at the same time. Which accords with the RoHS standard.

2 Features

- Low on resistance
- Low gate charge
- Fast switching
- Low reverse transfer capacitances
- 100% single pulse avalanche energy test
- 100% ΔV_{DS} test

3 Applications

- Motor control and drive
- Battery management
- UPS (Uninterruptible Power Supplies)

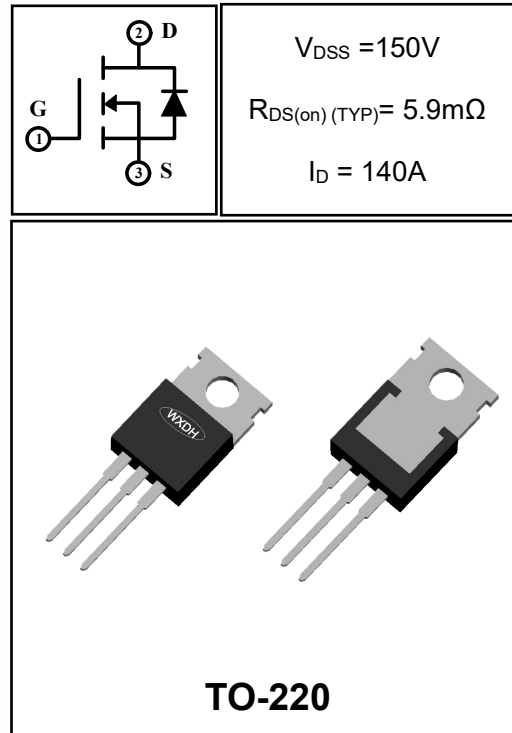

4 Electrical Characteristics

4.1 Absolute Maximum Ratings (T_c=25°C, unless otherwise noted)

Parameter		Symbol	Rating	Units
Drain-to-Source Voltage		V _{DSS}	150	V
Gate-to-Source Voltage		V _{GSS}	±20	V
Continuous Drain Current	T _c =25°C	I _D	140	A
	T _c =100°C		99	A
Pulsed Drain Current ⁽¹⁾		I _{DM}	560	A
Single Pulse Avalanche Energy ⁽⁴⁾		E _{AS}	1024	mJ
Power Dissipation	T _a =25°C	P _{tot}	2.3	W
	T _c =25°C		300	W
Junction Temperature Range		T _j	-55~175	°C
Storage Temperature Range		T _{stg}	-55~175	°C

4.2 Thermal Characteristics

Parameter	Symbol	Value			Units
		Min	Typ	Max	
Thermal Resistance, Junction to Case-sink	R _{thJC}	—	0.35	0.5	°C/W
Thermal Resistance, Junction to Ambient	R _{thJA}	—	50	65	°C/W

4.3 Electrical Characteristics (Tc=25°C, unless otherwise noted)

Parameter	Symbol	Test Condition	Value			Units
			Min	Typ	Max	
Off Characteristics						
Drain-to-Source Breakdown Voltage	BV _{DSS}	I _D =250μA, V _{GS} =0V	150	--	--	V
Drain-to-Source Leakage Current	I _{DSS}	V _{DS} =150V, V _{GS} =0V, T _C =25°C	--	--	1	μA
		V _{DS} =150V, V _{GS} =0V, T _C =125°C	--	--	100	μA
Gate-to-Source Leakage Current	I _{GSS}	V _{GS} =±20V, V _{DS} =0V	--	--	±100	nA
On Characteristics						
Gate Threshold Voltage	V _{GS(th)}	V _{DS} =V _{GS} , I _D =250μA	2	3	4	V
Drain-to-Source on-state Resistance	R _{DS(on)}	V _{GS} =10V, I _D =60A	--	5.9	7.0	mΩ
Transconductance	G _{fs}	V _{DS} =5V, I _D =60A	--	86	--	S
Dynamic Characteristics						
Input Capacitance	C _{iss}	V _{GS} =0V, V _{DS} =75V, f=1.0MHz	--	3947	--	pF
Output Capacitance	C _{oss}		--	598	--	
Reverse Transfer Capacitance	C _{rss}		--	17	--	
Gate Resisitance	R _G	V _{DS} =0V, V _{GS} =0V, F=1MHz	--	0.9	--	Ω
Switching Characteristics						
Turn-on Delay Time	t _{d(on)}	V _{GS} =10V, V _{DS} =75V, I _D =60A, R _G =3Ω	--	26	--	nS
Turn-on Rise Time	t _r		--	38	--	
Turn-off Delay Time	t _{d(off)}		--	46	--	
Turn-off Fall Time	t _f		--	25	--	
Total Gate Charge	Q _g	I _D =70A, V _{DS} =75V, V _{GS} =10V	--	56.8	--	nC
Gate-to-Source Charge	Q _{gs}		--	22	--	
Gate-to-Drain("Miller") Charge	Q _{gd}		--	15	--	
Gate plateau voltage	V _{plateau}		--	6.3	--	
Drain-Source Diode Characteristics						
Diode Forward Voltage ⁽³⁾	V _{SD}	V _{GS} =0V, I _S =60A	--	--	1.2	V
Diode Forward Current	I _S		--	--	140	A
Reverse Recovery Time ⁽³⁾	trr	T _J =25°C, I _F =60A	--	95	--	nS
Reverse Recovery Charge ⁽³⁾	Q _{rr}	dI _F /dt=100A/μS, V _{GS} =0V	--	157	--	nC

Notes:

- 1: Repetitive rating, pulse width limited by maximum junction temperature.
- 2: Surface mounted on FR4 Board, t≤10sec.
- 3: Pulse width ≤ 300μs, duty cycle ≤ 2%.
- 4: L=0.5mH, V_{DD}=50V, V_G=150V, Start T_J=25°C.

5 Typical characteristics diagrams

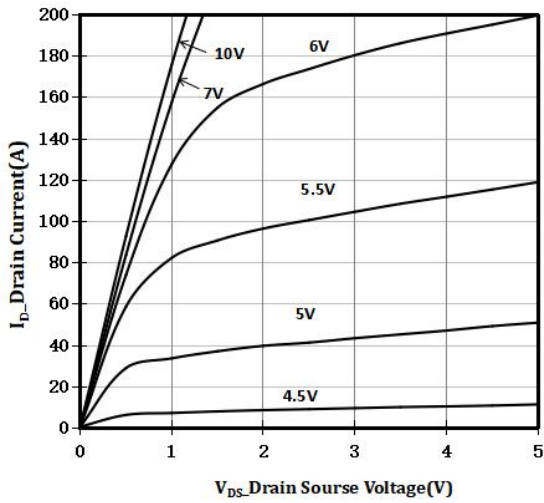

Fig 1 Output Characteristics

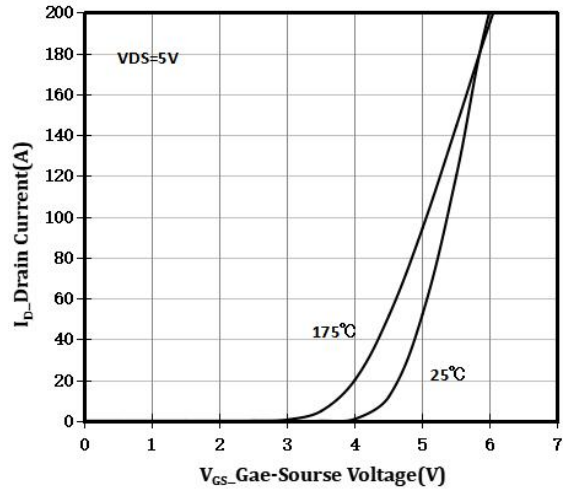

Fig 2 Transfer Characteristics

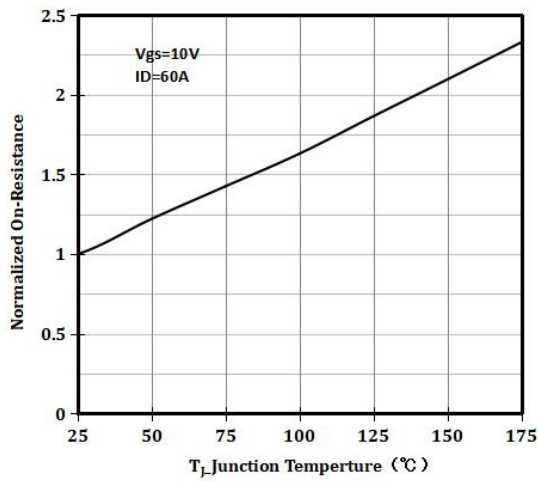

Fig 3 RDSON vs Junction Temperature

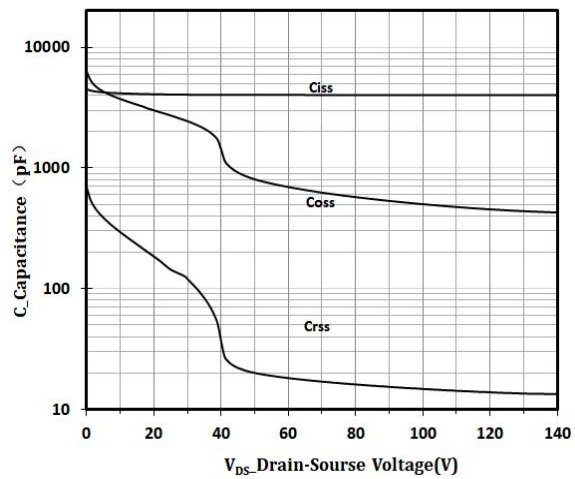

Fig 4 Capacitance vs Vds

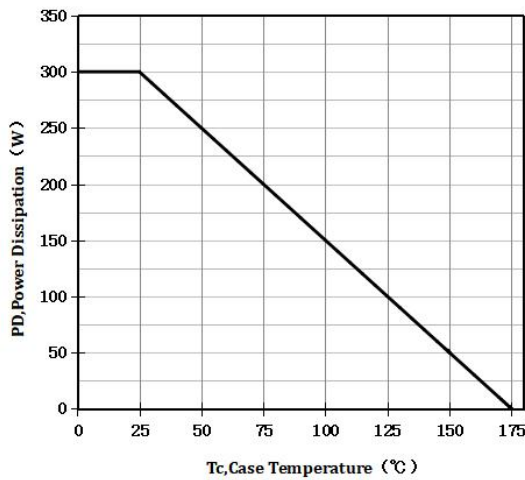

Fig 5 Power De-rating

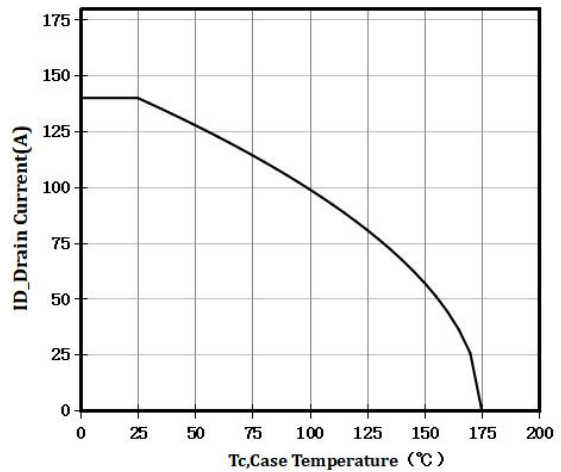

Fig 6 ID Current De-rating

5 Typical characteristics diagrams(continues)

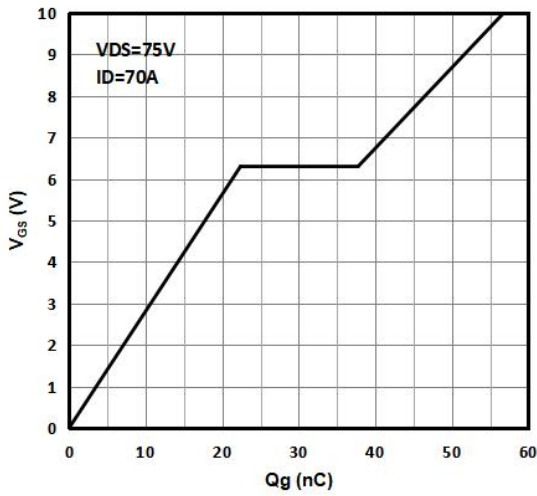

Fig 7 Gate Charge Figure

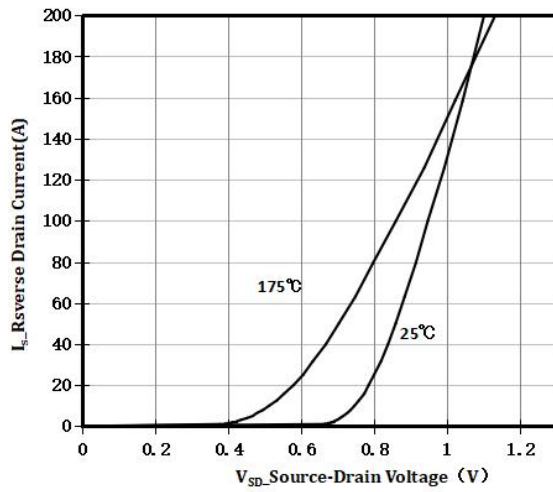

Fig 8 Source-Drain Diode Forward

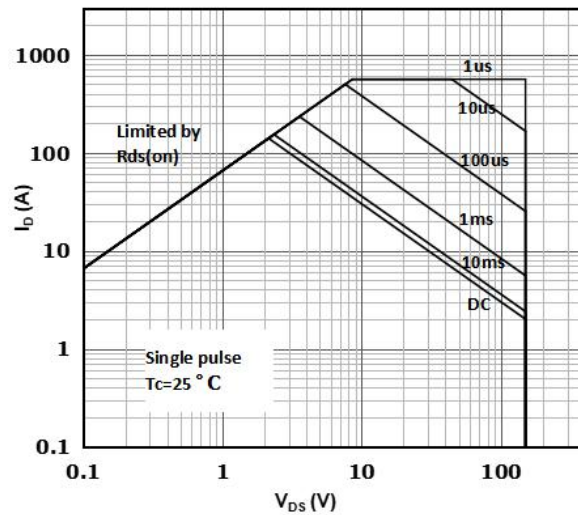

Fig 9 SOA

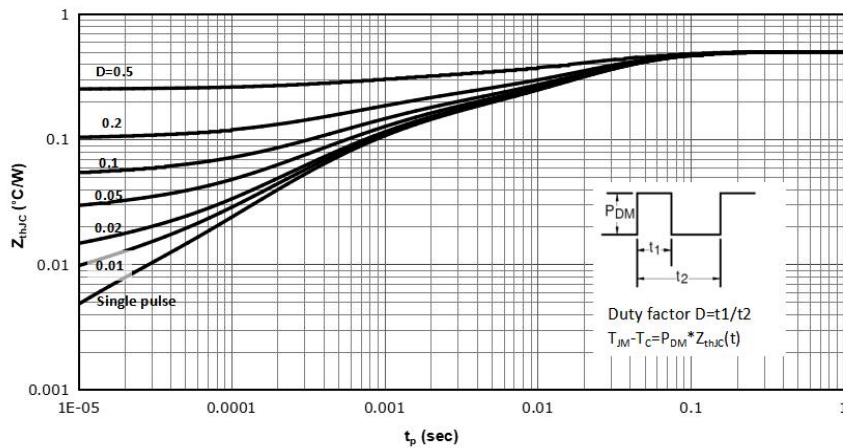
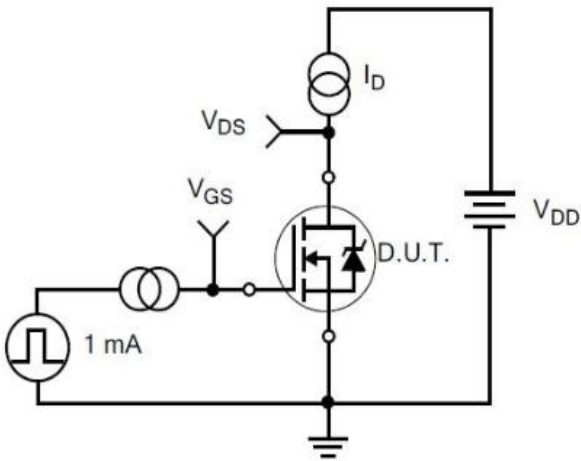
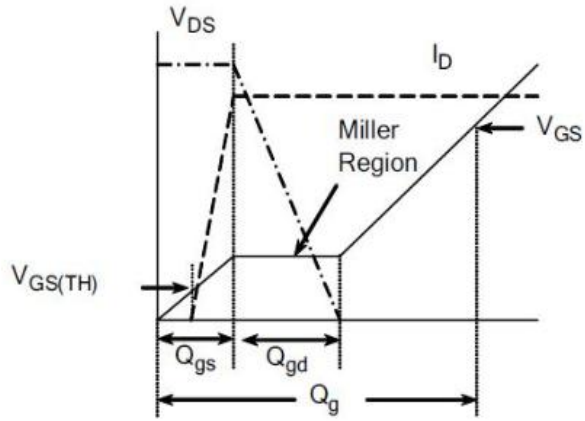

Fig 10 Normalized Maximum Transient Thermal Impedance

6 Typical Test Circuit and Waveform



1) Gate Charge Test Circuit



2) . Gate Charge Waveform

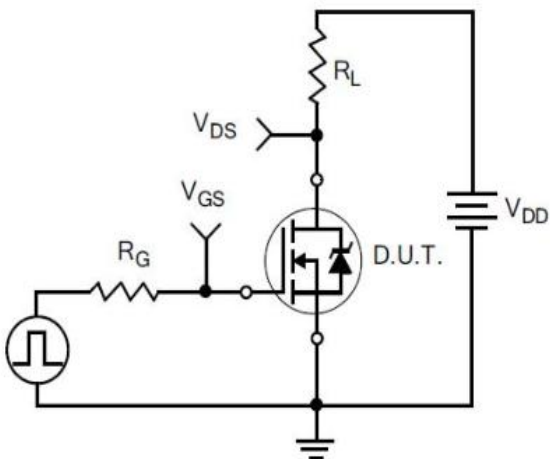

3) Resistive Switching Test Circuit

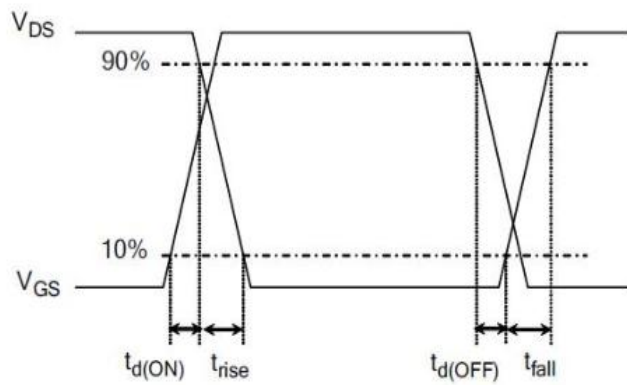

4) Resistive Switching Waveforms

6 Typical Test Circuit and Waveform(continues)

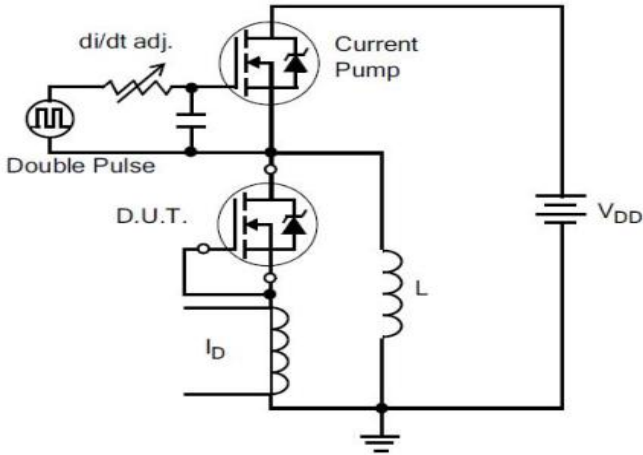

5) Diode Reverse Recovery Test Circuit

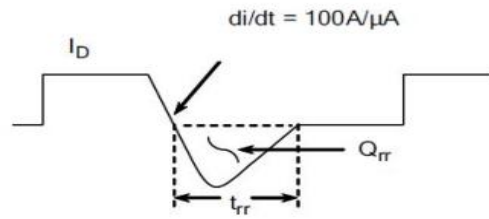

6) Diode Reverse Recovery Waveform

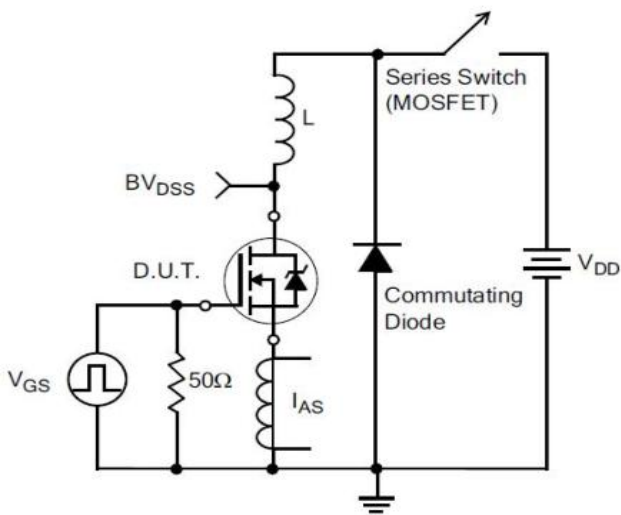

7) . Unclamped Inductive Switching Test Circuit

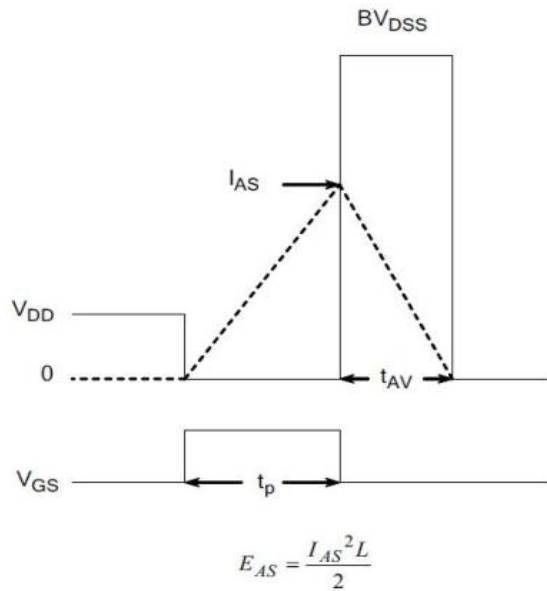

8) Unclamped Inductive Switching Waveforms

7 Dimensions

TO-220C PACKAGE OUTLINE DIMENSIONS

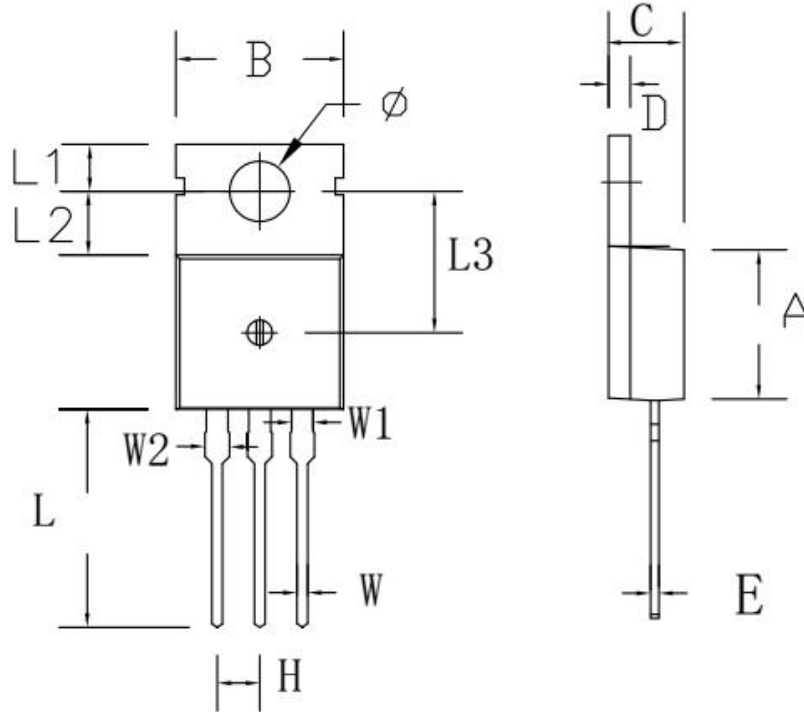

Symbol	Dimensions In Millimeters		Dimensions In Inches	
	min.	max.	min.	max.
A	8.80	9.30	0.346	0.366
B	9.70	10.30	0.382	0.406
C	4.25	4.75	0.167	0.187
D	1.20	1.45	0.047	0.057
E	0.40	0.60	0.016	0.024
H	2.54 TYP		0.100 TYP	
W	0.60	0.95	0.024	0.037
W1	1.05	1.45	0.041	0.057
W2	1.20	1.60	0.047	0.063
L	12.60	13.40	0.496	0.528
L1	2.45	2.95	0.096	0.116
L2	3.45	3.95	0.136	0.156
L3	8.15	8.65	0.321	0.341
Φ	3.50	3.90	0.138	0.154

8 Product Specifications and Packaging Models

Product Model	Package Type	Mark Name	RoHS	Package	Quantity
DSG070N15NA	TO-220	DSG070N15NA	Pb-free	Tube	1000/box

9 Attentions

- Jiangsu Donghai Semiconductor Technology CO.,LTD. reserves the right to change the specification without prior notice! The customer should obtain the latest version of the information before making the order and verify that the information is complete and up to date.
- It is the responsibility of the purchaser for any failure or failure of any semiconductor product under certain conditions. It is the responsibility of the purchaser to comply with safety standards and to take safety measures in the system design and machine manufacturing of Donghai products in order to avoid potential risk of failure. Injury or property damage.
- Product promotion is endless, our company will be dedicated to provide customers with better products.

10 Appendix

Revision history:

Date	REV.	Description	Page
2022.11.05	1.0	Original	9