

70A 60V N-channel Enhancement Mode Power MOSFET

1 Description

These N-channel enhancement mode power mosfets used advanced trench technology design, provided excellent $R_{DS(on)}$ and low gate charge. Which accords with the RoHS standard.

2 Features

- AEC-Q101 qualified
- MSL1 up to 260°C peak reflow
- 175°C operating temperature
- Green Product (RoHS compliant)
- Fast switching
- 100% single pulse avalanche energy test

3 Applications

- Automotive application
- Power switching applications
- Inverter management system
- Power tools

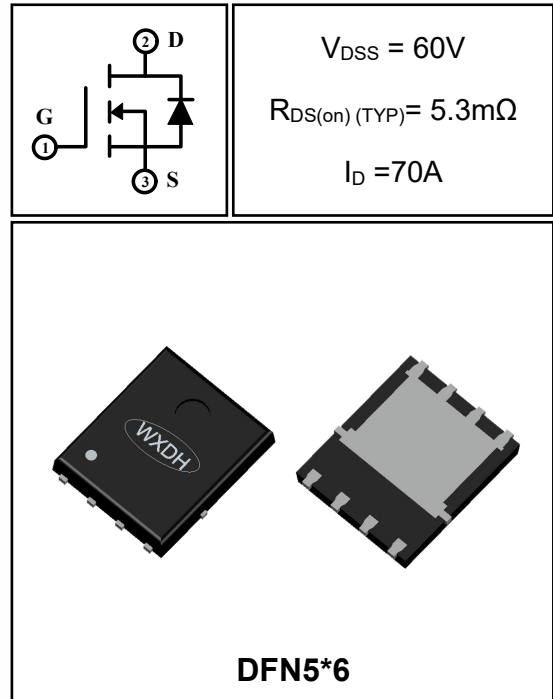

4 Electrical Characteristics

4.1 Absolute Maximum Ratings (T_c=25°C, unless otherwise noted)

Parameter	Symb	Rating	Units
Drain-to-Source Voltage	V _{DSS}	60	V
Gate-to-Source Voltage	V _{GSS}	±20	V
Continuous Drain Current	I _D	T _c =25°C	70
		T _c =100°C	50
Pulsed Drain Current ⁽¹⁾	I _{DM}	280	A
Single Pulse Avalanche Energy ⁽⁴⁾	E _{AS}	400	mJ
Power Dissipation	P _{tot}	T _a =25°C	3
		T _c =25°C	71
Junction Temperature Range	T _j	-55~175	°C
Storage Temperature Range	T _{stg}	-55~175	°C

4.2 Thermal Characteristics

Parameter	Symbol	Min	Typ	Max	Units
Thermal Resistance, Junction to Case-sink	R _{thJC}	---	2.1	2.7	°C/W
Thermal Resistance, Junction to Ambient (PCB Mount)	R _{thJA}	---	---	50	°C/W

4.3 Electrical Characteristics (Tc=25°C, unless otherwise noted)

Parameter	Symbol	Test Condition	Value			Units
			Min	Typ	Max	
Off Characteristics						
Drain-to-Source Breakdown Voltage	BV _{DSS}	I _D =250μA, V _{GS} =0V	60	--	--	V
Drain-to-Source Leakage Current	I _{DSS}	V _{DS} =60V, V _{GS} =0V, T _C =25°C	--	--	1	μA
		V _{DS} =60V, V _{GS} =0V, T _C =125°C	--	--	100	μA
Gate-to-Source Leakage Current	I _{GSS}	V _{GS} =±20V, V _{DS} =0V	--	--	±100	nA
On Characteristics						
Gate Threshold Voltage	V _{GS(th)}	V _{DS} =V _{GS} , I _D =250μA	2.5	3	3.5	V
Drain-to-Source on-state Resistance	R _{DS(on)}	V _{GS} =10V, I _D =60A	--	5.3	5.7	mΩ
Dynamic Characteristics						
Input Capacitance	C _{iSS}	V _{GS} =0V, V _{DS} =30V, f=1.0MHz	--	2983	--	pF
Output Capacitance	C _{oss}		--	263	--	
Reverse Transfer Capacitance	C _{rss}		--	202	--	
Gate Resisitance	R _G	V _{DD} =0V, V _{GS} =0V, F=1MHz	--	1.7	--	Ω
Switching Characteristics						
Turn-on Delay Time	t _{d(on)}	V _{gs} =10V, V _{ds} =30V, I _d =60A, R _g =3Ω	--	14	--	nS
Turn-on Rise Time	t _r		--	48	--	
Turn-off Delay Time	t _{d(off)}		--	34	--	
Turn-off Fall Time	t _f		--	18	--	
Total Gate Charge	Q _g	V _{gs} =10V, V _{ds} =30V, I _d =60A	--	63	--	nC
Gate-to-Source Charge	Q _{gs}		--	22	--	
Gate-to-Drain("Miller")	Q _{gd}		--	22	--	
Drain-Source Diode Characteristics						
Diode Forward Voltage ⁽³⁾	V _{SD}	V _{GS} =0V, I _S =60A	--	--	1.2	V
Diode Forward Current	I _S		--	--	70	A
Reverse Recovery Time ⁽³⁾	t _{rr}	T _J =25°C, I _F =30A dI _F /dt=100A/us, V _{GS} =0V	--	17	--	nS
Reverse Recovery	Q _{rr}		--	8.5	--	nC

Notes:

- 1: Repetitive rating, pulse width limited by maximum junction temperature.
- 2: Surface mounted on FR4 Board, t≤10sec.
- 3: Pulse width ≤ 300μs, duty cycle ≤ 2%.
- 4: L=0.5mH, V_{DD}=20V, V_{GATE}=20V, Start T_J=25°C.

5. Typical characteristics diagrams

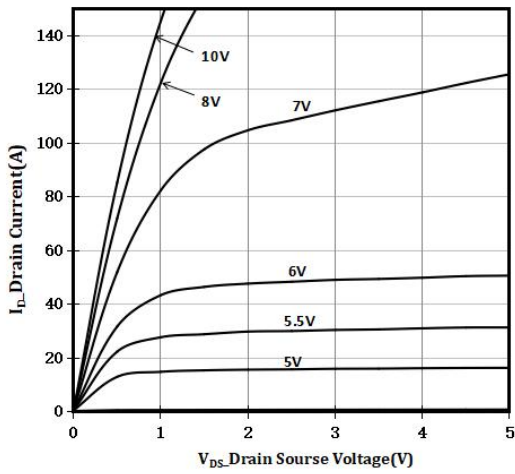

Figure 1 Output Characteristics

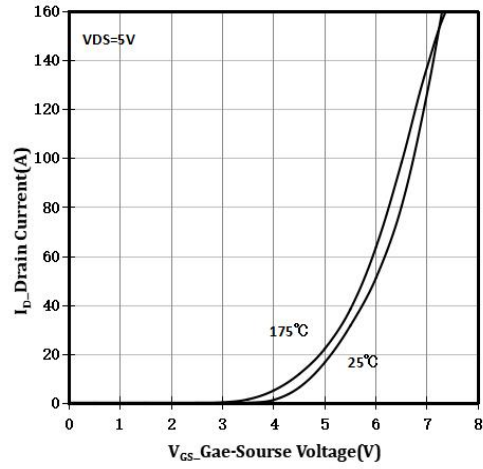

Figure 2 Transfer Characteristics

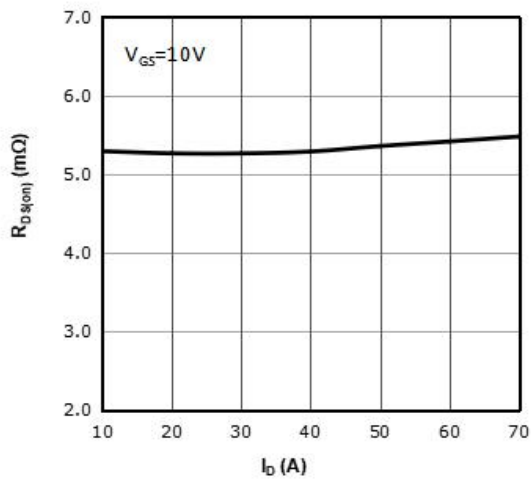

Figure 3 Rdson- Drain Current

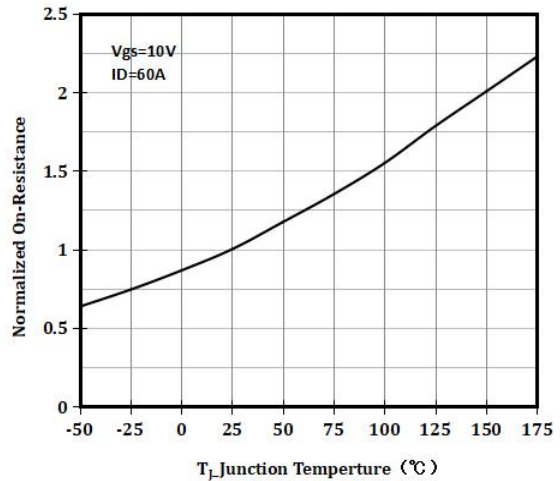

Figure 4 Rdson-Junction Temperature

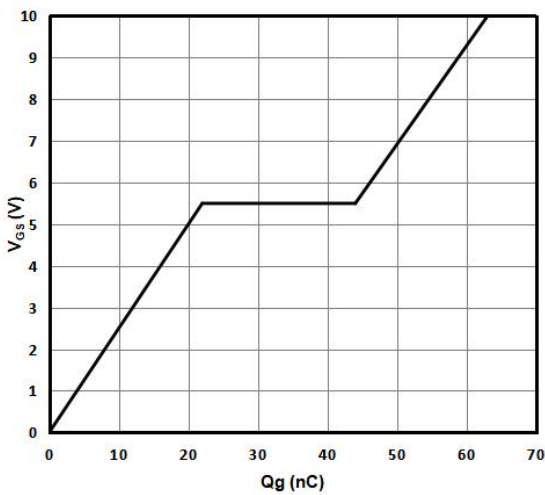

Figure 5 Gate Charge

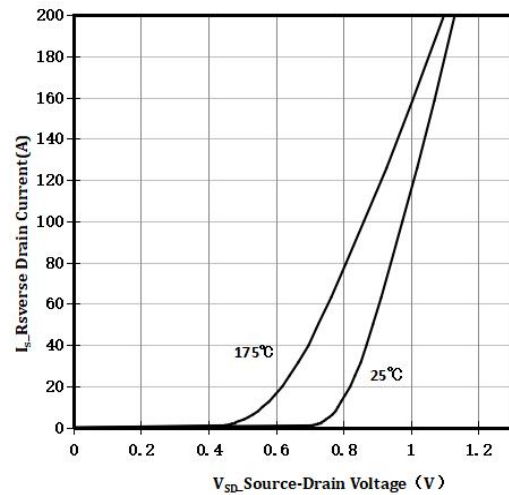

Figure 6 Source- Drain Diode Forward

5 Typical characteristics diagrams(continues)

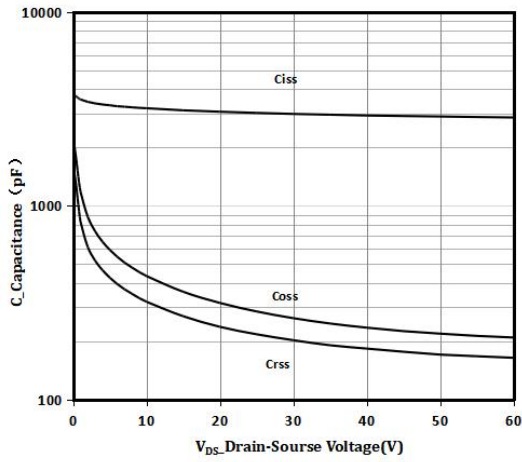

Figure 7 Capacitance vs Vds

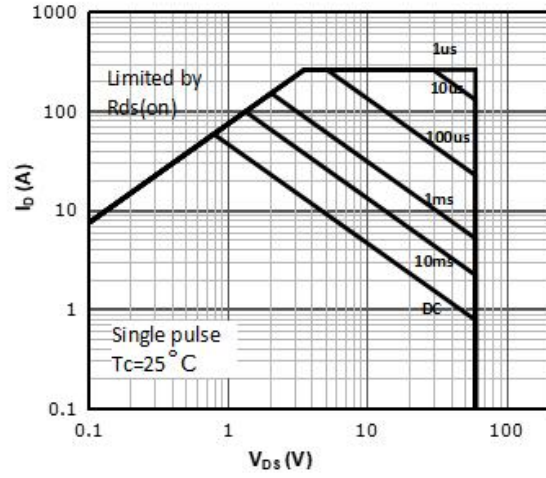

Figure 8 Safe Operation Area

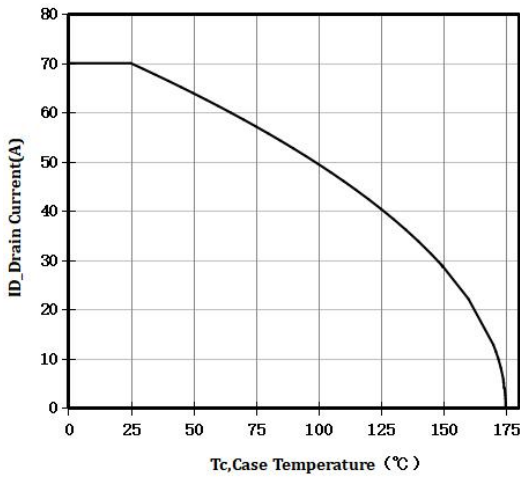

Figure 9. ID Current De-rating

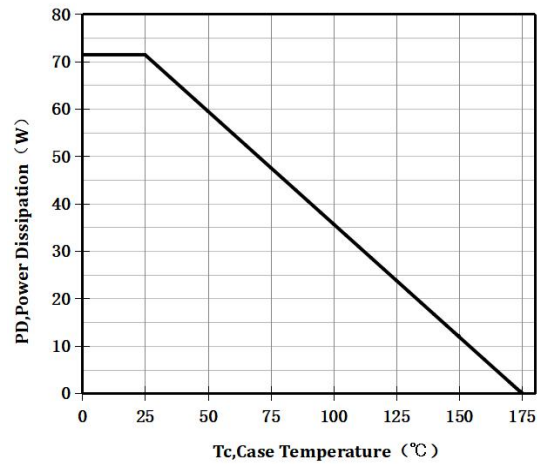

Figure 10. Power De-rating

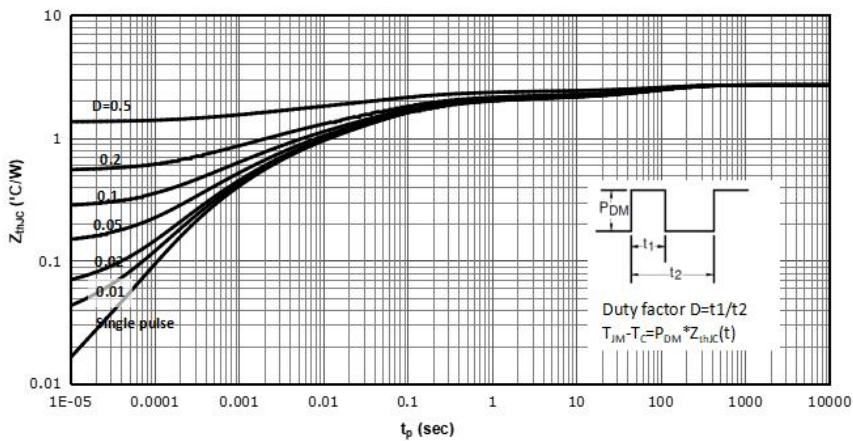
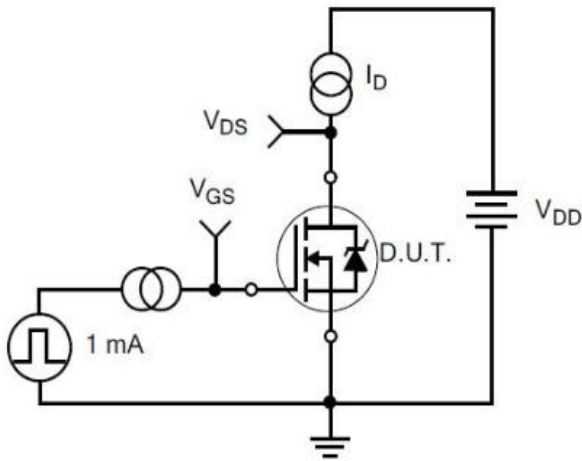
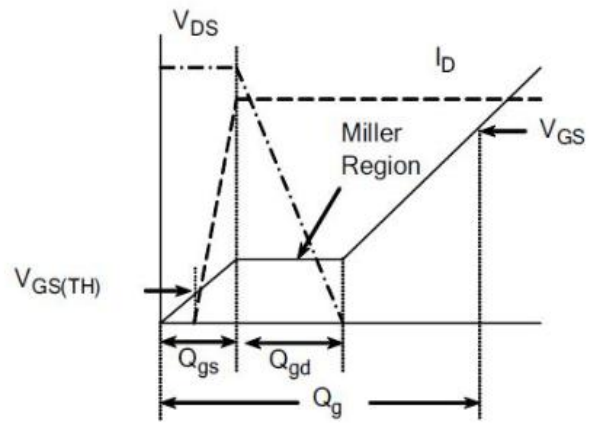

Fig 11. Normalized Maximum Transient Thermal Impedance

6 Typical Test Circuit and Waveform



1) Gate Charge Test Circuit



2) . Gate Charge Waveform

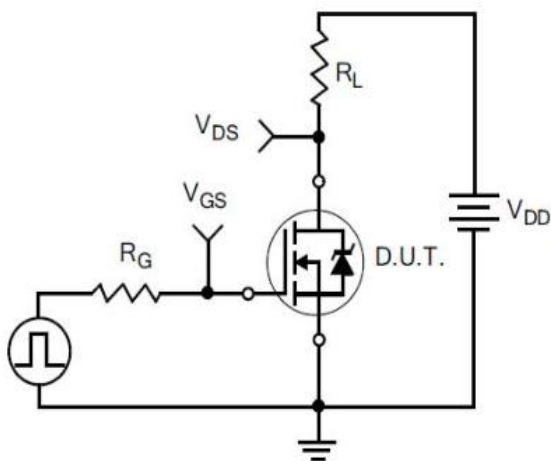

3) Resistive Switching Test Circuit

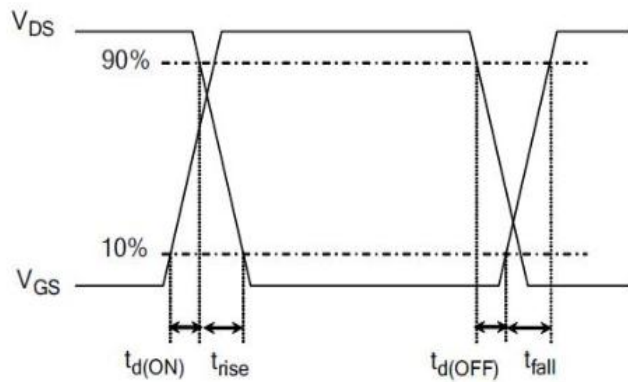

4) Resistive Switching Waveforms

6 Typical Test Circuit and Waveform(continues)

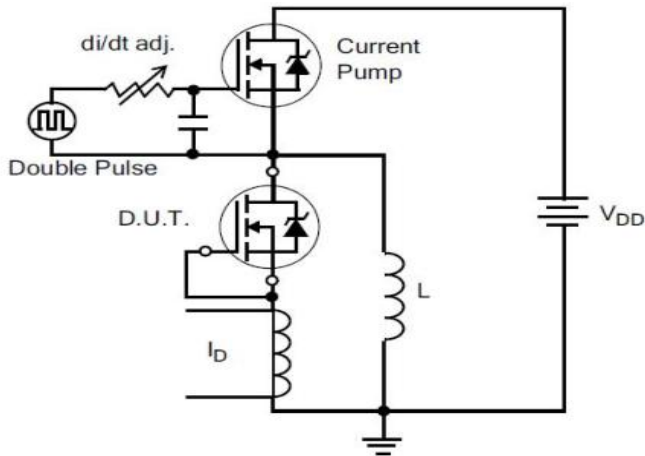

5) Diode Reverse Recovery Test Circuit

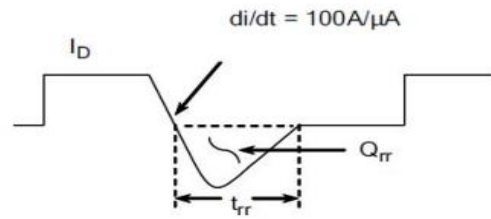

6) Diode Reverse Recovery Waveform

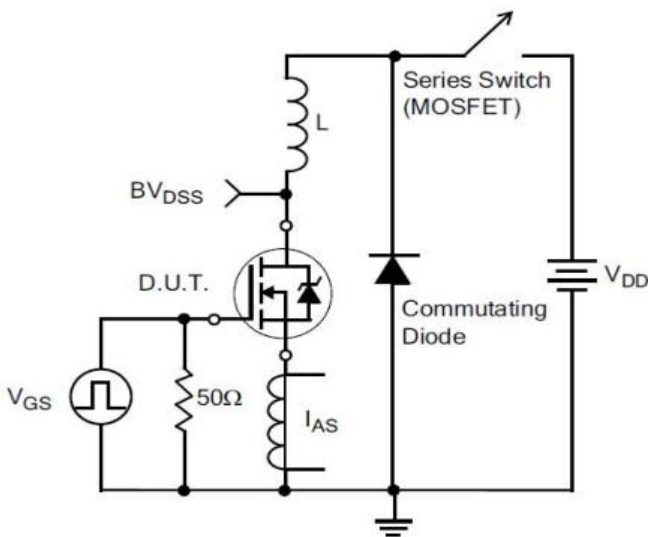

7) . Unclamped Inductive Switching Test Circuit

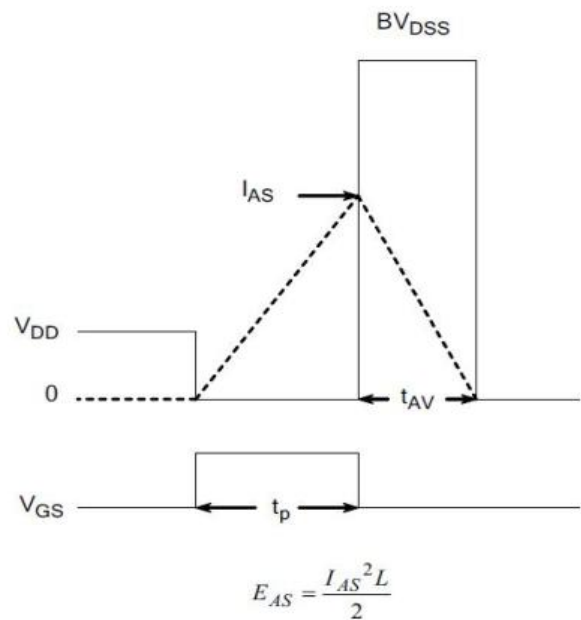

8) Unclamped Inductive Switching Waveforms

7 Product Names Rules

D A S G X X X N E X X N A

LOGO Code: D

Automotive
Blank=Non-Automotive
A=Automotive

Product Line Code
T=Trench MOS
S=SGT MOS
P=Planar MOS

Packaging Code
220F: F 220: G
262: I 263: E

RDSON Specification Code
With 3 Digitals,
For Example:
045 on behalf of 4.5mΩ
050 on behalf of 5.0mΩ
155 on behalf of 15.5mΩ

Channel Polarity Code
N on behalf of N channel
P on behalf of P channel

Reliability level (Last Letter)
Blank=Consumer/Industrial
A=AEC-Q101 Qualified

Vth Level	Vth(V)	Driver(V)
N=Normal	2.5~4.0	10~15
L=Logic	1.2~2.4	4.5~8.0
S=Super Logic	0.8~1.2	2.5
U=UltraLogic	0.5~0.8	1.8

Rated Voltage Code
With 2-3 Digitals,
For Example:
06 on behalf of 60V
08 on behalf of 80V
045 on behalf of 45V

Special Function Code
E on behalf of build-in ESD
Nothing on behalf of not ESD

8 Product Specifications and Packaging Models

Product Model	Package Type	Mark Name	RoHS	Package	Quantity
DATP057N06N	DFN5*6-8	DATP057N06N	Pb-free	Tape & Reel	3000/box

9 Dimensions

PPAK5x6 PACKAGE INFORMATION

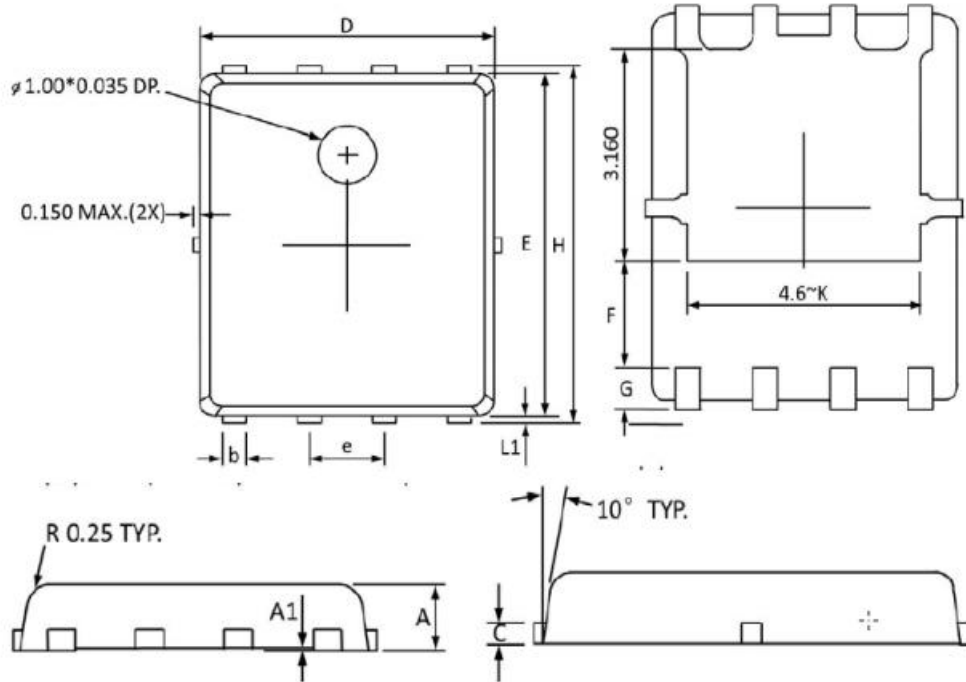

Symbol	Dimensions In Millimeters		Dimensions In Inches	
	Min	Max	Min	Max
A	0.800	1.000	0.032	0.039
A1	0.000	0.005	0.000	0.000
b	0.350	0.490	0.014	0.019
C	0.254 Ref		0.254 Ref	
D	4.900	5.100	0.193	0.200
E	5.700	5.900	0.225	0.232
e	1.27 BSC		1.27 BSC	
F	1.600 Ref		1.600 Ref	
G	0.600 Ref		0.600 Ref	
H	5.950	6.200	0.235	0.244
L1	0.100	0.180	0.004	0.007
K	3.200 Ref		3.200 Ref	

10 Attentions

- Jiangsu Donghai Semiconductor Technology CO.,LTD. reserves the right to change the specification without prior notice! The customer should obtain the latest version of the information before making the order and verify that the information is complete and up to date.
- It is the responsibility of the purchaser for any failure or failure of any semiconductor product under certain conditions. It is the responsibility of the purchaser to comply with safety standards and to take safety measures in the system design and machine manufacturing of Donghai products in order to avoid potential risk of failure. Injury or property damage.
- Product promotion is endless, our company will be dedicated to provide customers with better products.

11 Appendix

Revision history:

Date	REV.	Description	Page
2022.09.10	1.0	Original	9