

52A 650V N-channel SiC Power MOSFET

1 Description

This product family offers state of the art performance. It is designed for high frequency applications where high efficiency and high reliability are required.

2 Features

- Higher System Efficiency
- Reduced Cooling Requirements
- Increased Power Density
- Increased System Switching Frequency

3 Applications

- EV Charging
- Server Power Supplies
- Solar PV Inverters
- UPS
- DC/DC Converters

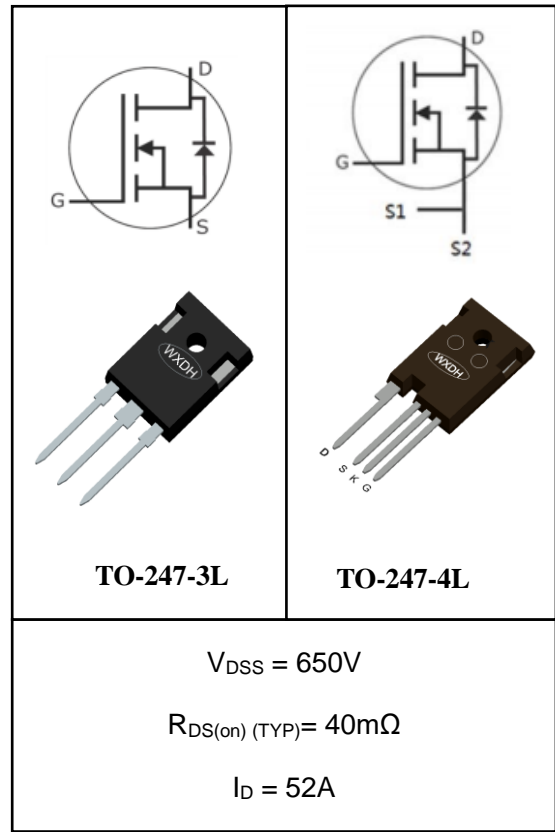

4 Electrical Characteristics

4.1 Absolute Maximum Rating (T_c=25°C, unless otherwise noted)

Parameter	Symbol	Test Conditions	Value	Units
Drain-to-Source Voltage	V _{DSmax}	V _{GS} =0V, I _D =100μA	650	V
Gate-Source Voltage	V _{GSmax}	Absolute maximum values	-8/+22	V
Gate-Source Voltage	V _{GSop}	Recommended operational values	-4/+18	V
Continuous Drain Current	I _D	V _{GS} =18V, T _C =25°C	52	A
		V _{GS} =18V, T _C =100°C	37	A
Pulsed Drain Current ⁽¹⁾	I _{D(PULSE)}	Pulse width tp limited by T _{Jmax}	140	A
Power Dissipation	P _D	T _c =25°C, T _J =175°C	176	W
Junction Temperature Range	T _j		-40~175	°C
Storage Temperature Range	T _{stg}		-40~175	°C

4.2 Thermal Characteristics

Parameter	Symbol	Rating	Unit
Thermal Resistance, Junction to Case-sink	R _{thJC}	0.85	°C/W
Thermal Resistance, Junction to Ambient	R _{thJA}	40	°C/W

4.3 Electrical Characteristics (Tc=25°C, unless otherwise noted)

Parameter	Symbol	Test Condition	Value			Units
			Min	Typ	Max	
Drain-to-Source Breakdown Voltage	BV _{DSS}	I _D =1mA, V _{GS} =0V	650	---	---	V
Zero Gate Voltage Drain Current	I _{DSS}	V _{DS} =650V, V _{GS} =0V	---	1	100	μA
Gate-to-Source Leakage	I _{GSS+}	V _{DS} =0V, V _{GS} =22V	---	10	250	nA
Gate Threshold Voltage	V _{GS(th)}	V _{DS} =V _{GS} , I _D =10mA	1.8	2.6	4.3	V
Drain-to-Source on-state Resistance	R _{DS(on)}	V _{GS} =18V, I _D =20A	---	40	52	mΩ
		V _{GS} =18V, I _D =20A, T _J =175°C	---	50	---	
Input Capacitance	C _{iss}	V _{GS} =0V, V _{DS} =400V, f=1.0MHz, V _{AC} =25mV	---	1500	---	pF
Output Capacitance	C _{oss}		---	135	---	
Reverse Transfer Capacitance	C _{rss}		---	15	---	
Turn-On Switching Energy	E _{ON}	V _{DS} =400V, V _{GS} =-4V/18V I _D =20A, R _{G(ext)} =2.5Ω, L=100μH	---	48	---	μJ
Turn-Off Switching Energy	E _{OFF}		---	62	---	
Turn-on Delay Time	t _{d(on)}	V _{DS} =400V, V _{GS} =-4V/18V, I _D =20A, R _{G(ext)} =2.5Ω, R _L =20Ω	---	13	---	ns
Turn-on Rise Time	t _r		---	14	---	
Turn-off Delay Time	t _{d(off)}		---	27	---	
Turn-off Fall Time	t _f		---	8	---	
Internal Gate Resistance	R _{G(int)}	f=1MHz, V _{AC} =25mV	---	3	---	Ω
Total Gate Charge	Q _g	V _{DS} =400V, V _{GS} =-4V/18V, I _D =20A	---	82	---	nC
Gate-to-Source Charge	Q _{gs}		---	28	---	
Gate-to-Drain("Miller") Charge	Q _{gd}		---	30	---	
Drain-Source Diode Characteristics						
Diode Forward Voltage ⁽³⁾	V _{SD}	V _{GS} =-4V, I _{SD} =10A	---	4.2	---	V
		V _{GS} =-4V, I _{SD} =10A, T _J =175°C	---	3.8	---	V
Diode Forward Current	I _S	V _{GS} =-4V, T _C =25°C	---	---	29	A
Reverse Recovery Time ⁽³⁾	t _{rr}	V _R =400V, I _{SD} =20A	---	23	---	ns
Reverse Recovery Charge ⁽³⁾	Q _{rr}		---	80	---	nC
Peak Reverse Recovery Current	I _{rrm}		---	4	---	A

Notes:

- 1: Repetitive rating, pulse width limited by maximum junction temperature.
- 2: Surface mounted on FR4 Board, t_s≤10sec.
- 3: Pulse width ≤ 300μs, duty cycle ≤ 2%.

5 Typical characteristics diagrams

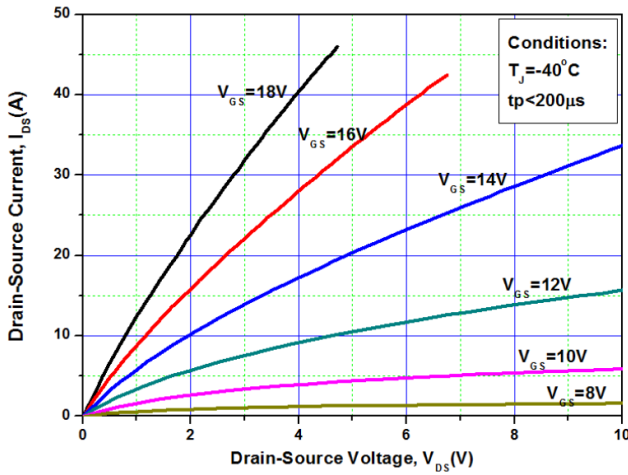

Figure 1. Output Characteristics $T_j = -40^\circ\text{C}$

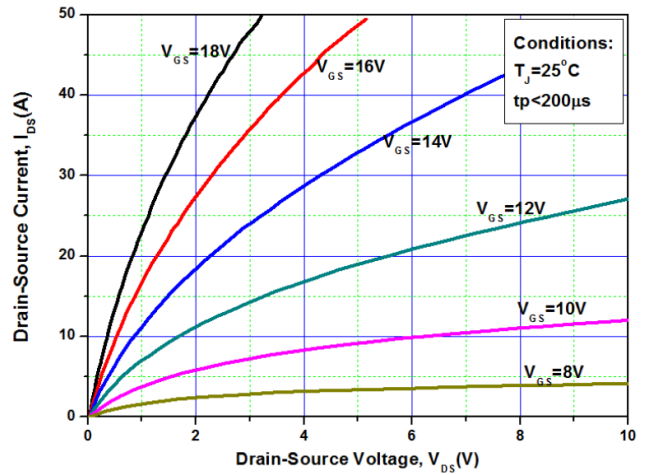

Figure 2. Output Characteristics $T_j = 25^\circ\text{C}$

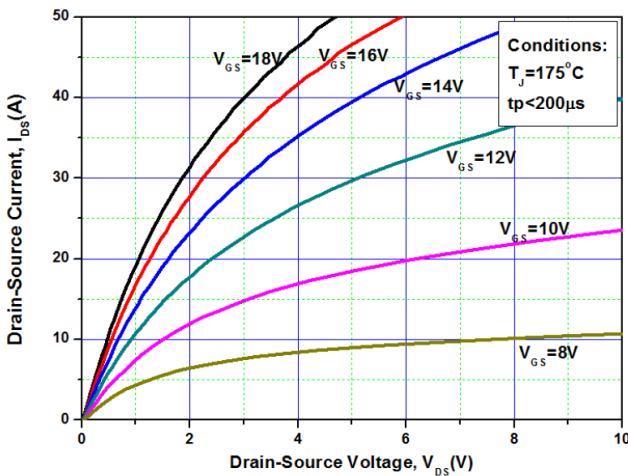

Figure 3. Output Characteristics $T_j = 175^\circ\text{C}$

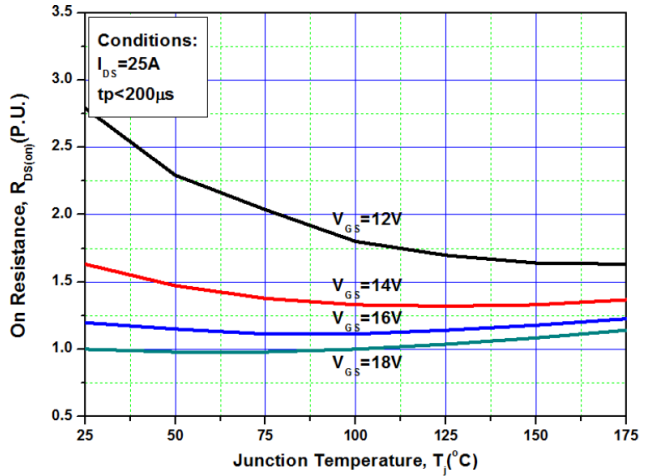

Figure 4. Normalized On-Resistance vs. Temperature

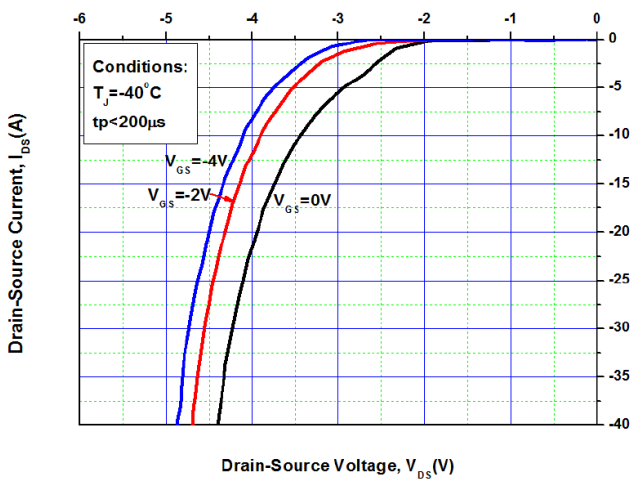

Figure 5. Body Diode Characteristic at -40°C

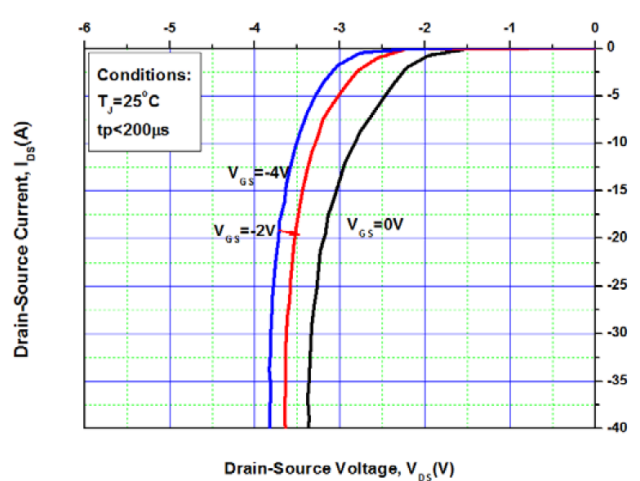

Figure 6. Body Diode Characteristic at 25°C

5 Typical characteristics diagrams(continues)

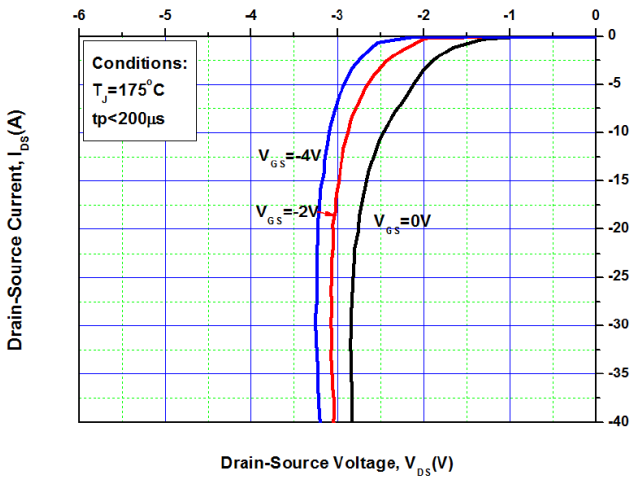

Figure 7. Body Diode Characteristic at 175°C

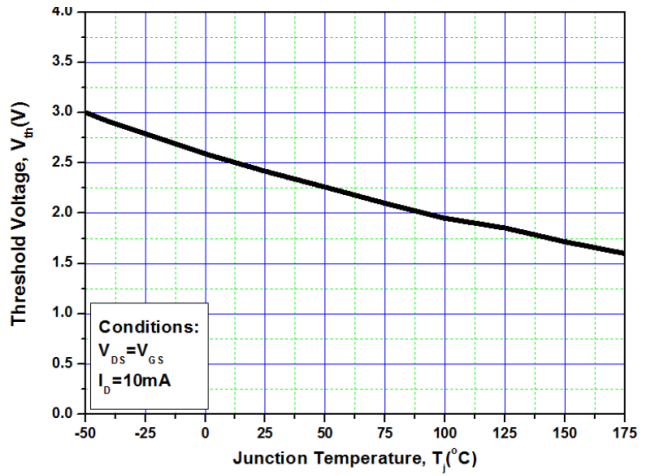

Figure 8. Threshold Voltage vs. Temperature

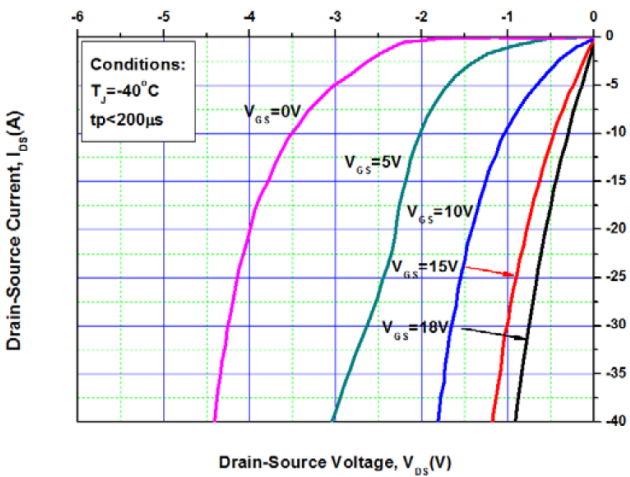

Figure 9. 3rd Quadrant Characteristic at -40°C

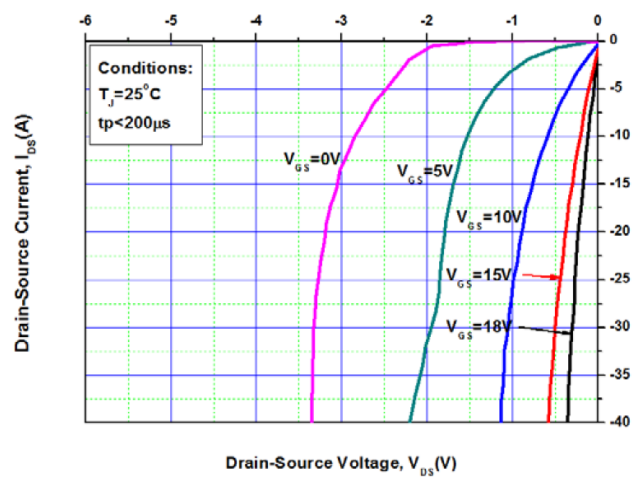

Figure 10. 3rd Quadrant Characteristic at 25°C

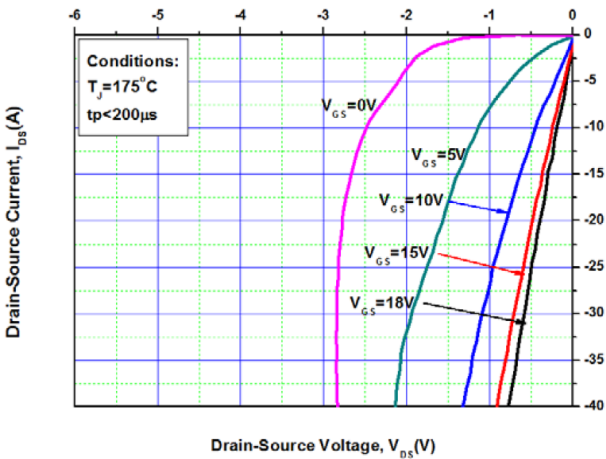

Figure 11. 3rd Quadrant Characteristic at 175°C

5 Typical characteristics diagrams(continues)

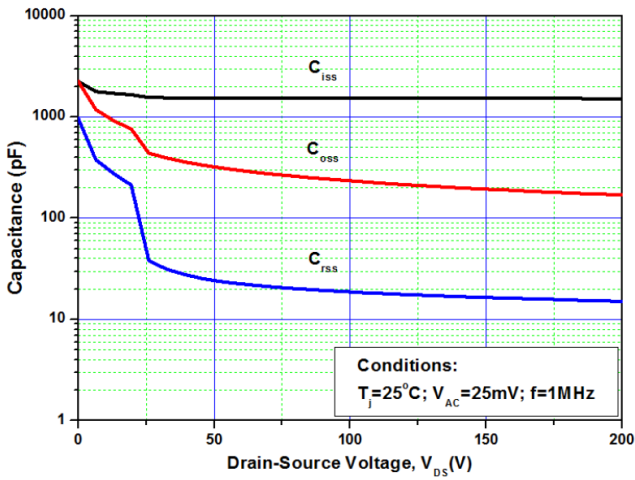

Figure 12. Capacitances vs. Drain-Source Voltage (0 - 200V)

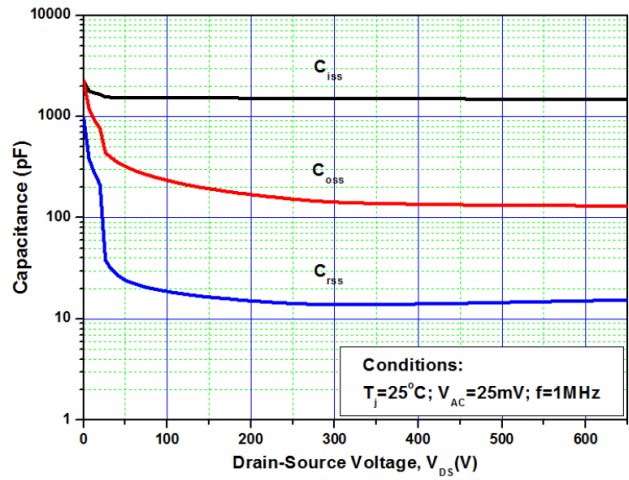

Figure 13. Capacitances vs. Drain-Source Voltage (0 - 650V)

6 Product Specifications and Packaging Models

Product Model	Package Type	Mark Name	RoHS	Package	Quantity
DCC040M65G2	TO-247-3L	DCC040M65G2	Pb-free	Tube	300/box
DCCF040M65G2	TO-247-4L	DCCF040M65G2	Pb-free	Tube	300/box

7 Dimensions

TO-247-3L PACK OUTLINE DIMENSIONS

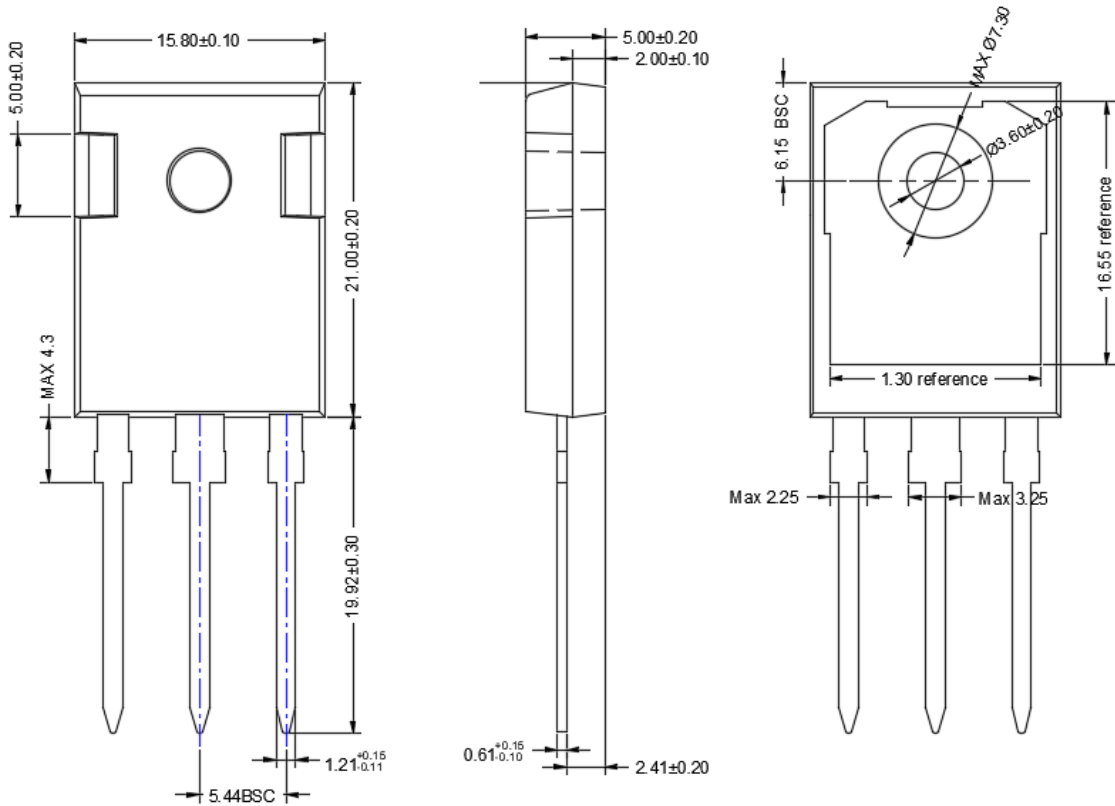

TO-247-4L PACK OUTLINE DIMENSIONS

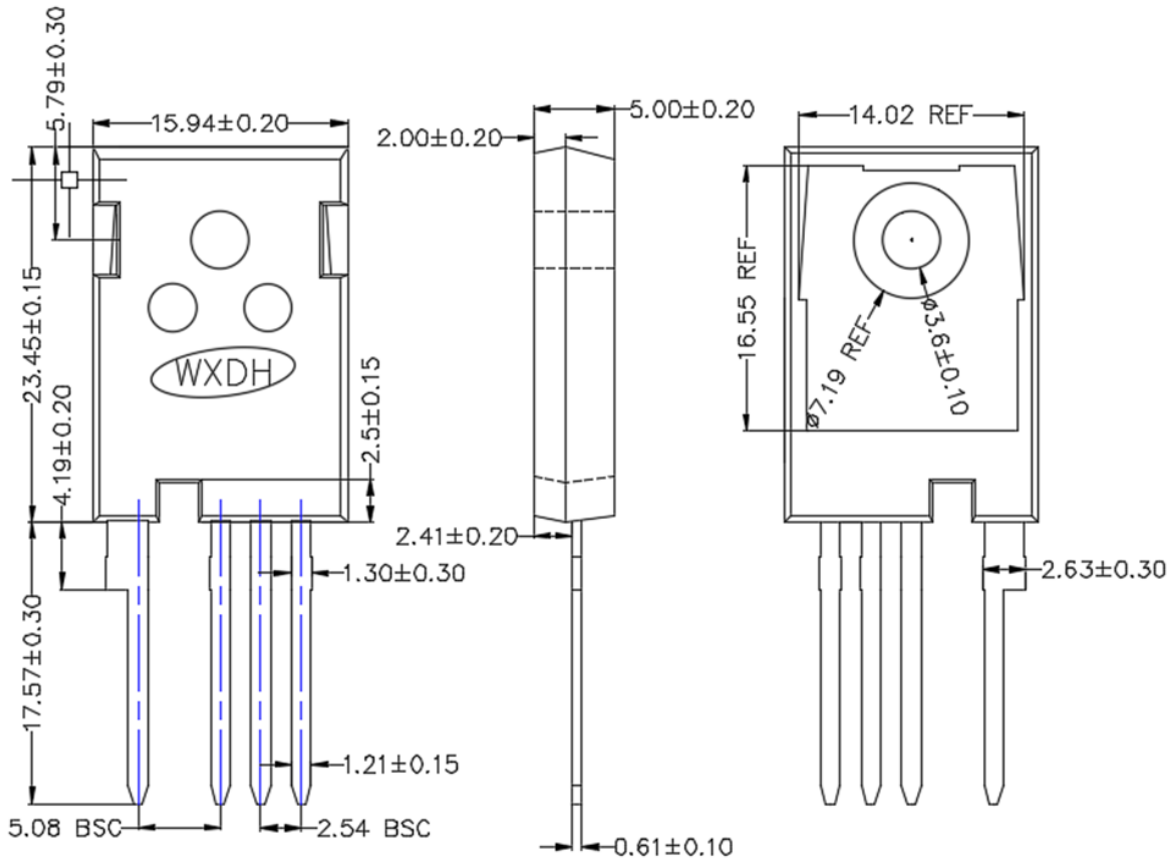

8 Attentions

- Jiangsu Donghai Semiconductor Technology CO.,LTD. reserves the right to change the specification without prior notice! The customer should obtain the latest version of the information before making the order and verify that the information is complete and up to date.
- It is the responsibility of the purchaser for any failure or failure of any semiconductor product under certain conditions. It is the responsibility of the purchaser to comply with safety standards and to take safety measures in the system design and machine manufacturing of Donghai products in order to avoid potential risk of failure. Injury or property damage.
- Product promotion is endless, our company will be dedicated to provide customers with better products.

9 Appendix

Revision history:

Date	REV.	Description	Page
2023.04.24	1.0	Original	7