

## 18A 1200V N-channel SIC Power MOSFET

### 1 Description

This product family offers state of the art performance. It is designed for high frequency applications where high efficiency and high reliability are required.

### 2 Features

- Higher System Efficiency
- Reduced Cooling Requirements
- Increased Power Density
- Increased System Switching Frequency

### 3 Applications

- Power Supplies.
- High Voltage DC/DC Converters.
- Motor Drives.
- Switch Mode Power Supplies
- Pulsed Power applications

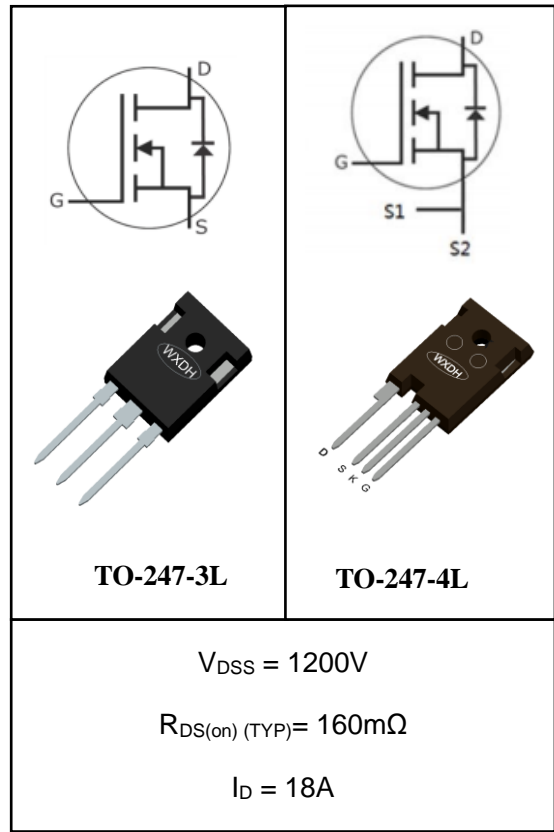

### 4 Electrical Characteristics

#### 4.1 Absolute Maximum Rating ( $T_c=25^\circ C$ , unless otherwise noted)

| Parameter                           | Symbol         | Test Conditions                         | Value   | Units      |
|-------------------------------------|----------------|---|---------|------------|
| Drain-to-Source Voltage             | $V_{DSmax}$    | $V_{GS}=0V, I_D=100\mu A$               | 1200    | V          |
| Gate-Source Voltage                 | $V_{GSmax}$    | Absolute maximum values                 | -10/+25 | V          |
| Gate-Source Voltage                 | $V_{GSop}$     | Recommended operational values          | -5/+20  | V          |
| Continuous Drain Current            | $I_D$          | $V_{GS}=20V, T_C=25^\circ C$            | 18      | A          |
|                                     |                | $V_{GS}=20V, T_C=100^\circ C$           | 12      | A          |
| Pulsed Drain Current <sup>(1)</sup> | $I_{D(PULSE)}$ | Pulse width $t_p$ limited by $T_{Jmax}$ | 40      | A          |
| Power Dissipation                   | $P_D$          | $T_c=25^\circ C, T_J=150^\circ C$       | 125     | W          |
| Junction Temperature Range          | $T_j$          |   | -55~150 | $^\circ C$ |
| Storage Temperature Range           | $T_{stg}$      |   | -55~150 | $^\circ C$ |

#### 4.2 Thermal Characteristics

| Parameter                                 | Symbol     | Typ | Max | Unit         |
|---|------------|-----|-----|--------------|
| Thermal Resistance, Junction to Case-sink | $R_{thJC}$ | 0.9 | --- | $^\circ C/W$ |
| Thermal Resistance, Junction to Ambient   | $R_{thJA}$ | --- | 40  | $^\circ C/W$ |

**4.3 Electrical Characteristics** (Tc=25°C, unless otherwise noted)

| Parameter                                 | Symbol              | Test Condition   | Value |     |     | Units |
|---|---------------------|--|-------|-----|-----|-------|
|   |                     |  | Min   | Typ | Max |       |
| Drain-to-Source Breakdown Voltage         | BV <sub>DSS</sub>   | I <sub>D</sub> =100μA, V <sub>GS</sub> =0V   | 1200  | --- | --- | V     |
| Zero Gate Voltage Drain Current           | I <sub>DSS</sub>    | V <sub>DS</sub> =1200V, V <sub>GS</sub> =0V  | ---   | 1   | 100 | μA    |
| Gate-to-Source Leakage Current            | I <sub>GSS+</sub>   | V <sub>DS</sub> =0V, V <sub>GS</sub> =25V  | ---   | 10  | 250 | nA    |
|   | I <sub>GSS-</sub>   | V <sub>DS</sub> =0V, V <sub>GS</sub> =-10V   | ---   | 10  | 250 | nA    |
| Gate Threshold Voltage                    | V <sub>GS(th)</sub> | V <sub>DS</sub> =V <sub>GS</sub> , I <sub>D</sub> =2.5mA   | 2.0   | 2.4 | 4.0 | V     |
|   |                     | V <sub>DS</sub> =V <sub>GS</sub> , I <sub>D</sub> =2.5mA, T <sub>J</sub> =150°C  | ---   | 1.8 | --- | V     |
| Drain-to-Source on-state Resistance       | R <sub>DS(on)</sub> | V <sub>GS</sub> =20V, I <sub>D</sub> =10A  | ---   | 160 | 196 | mΩ    |
|   |                     | V <sub>GS</sub> =20V, I <sub>D</sub> =10A, T <sub>J</sub> =150°C   | ---   | 280 | --- |       |
| Input Capacitance                         | C <sub>iss</sub>    | V <sub>GS</sub> =0V,<br>V <sub>DS</sub> =1000V,<br>f=1.0MHz,<br>V <sub>AC</sub> =25mV  | ---   | 890 | --- | pF    |
| Output Capacitance                        | C <sub>oss</sub>    |  | ---   | 54  | --- |       |
| Reverse Transfer Capacitance              | C <sub>rss</sub>    |  | ---   | 8.5 | --- |       |
| Turn-On Switching Energy                  | E <sub>ON</sub>     | V <sub>DS</sub> =800V, V <sub>GS</sub> =-5V/20V<br>I <sub>D</sub> =10A, R <sub>G(ext)</sub> =2.5Ω, L=200μH                       | ---   | 315 | --- | μJ    |
| Turn-Off Switching Energy                 | E <sub>OFF</sub>    |  | ---   | 63  | --- |       |
| Turn-on Delay Time                        | t <sub>d(on)</sub>  | V <sub>DS</sub> =800V,<br>V <sub>GS</sub> =-5V/20V,<br>I <sub>D</sub> =10A,<br>R <sub>G(ext)</sub> =2.5Ω,<br>R <sub>L</sub> =80Ω | ---   | 8   | --- | nS    |
| Turn-on Rise Time                         | t <sub>r</sub>      |  | ---   | 9   | --- |       |
| Turn-off Delay Time                       | t <sub>d(off)</sub> |  | ---   | 14  | --- |       |
| Turn-off Fall Time                        | t <sub>f</sub>      |  | ---   | 9   | --- |       |
| Internal Gate Resistance                  | R <sub>G(int)</sub> | f=1MHz, V <sub>AC</sub> =25mV  | ---   | 5.5 | --- | Ω     |
| Total Gate Charge                         | Q <sub>g</sub>      | V <sub>DS</sub> =800V,<br>V <sub>GS</sub> =-5V/20V,<br>I <sub>D</sub> =10A   | ---   | 49  | --- | nC    |
| Gate-to-Source Charge                     | Q <sub>gs</sub>     |  | ---   | 17  | --- |       |
| Gate-to-Drain("Miller") Charge            | Q <sub>gd</sub>     |  | ---   | 9   | --- |       |
| <b>Drain-Source Diode Characteristics</b> |                     |  |       |     |     |       |
| Diode Forward Voltage <sup>(3)</sup>      | V <sub>SD</sub>     | V <sub>GS</sub> =-5V, I <sub>SD</sub> =5A  | ---   | 4.2 | --- | V     |
|   |                     | V <sub>GS</sub> =-5V, I <sub>SD</sub> =5A, T <sub>J</sub> =150°C   | ---   | 3.9 | --- | V     |
| Diode Forward Current                     | I <sub>S</sub>      | T <sub>C</sub> =25°C   | ---   | --- | 23  | A     |
| Reverse Recovery Time <sup>(3)</sup>      | t <sub>rr</sub>     | V <sub>R</sub> =800V, I <sub>SD</sub> =10A   | ---   | 28  | --- | nS    |
| Reverse Recovery Charge <sup>(3)</sup>    | Q <sub>rr</sub>     |  | ---   | 50  | --- | nC    |
| Peak Reverse Recovery Current             | I <sub>rrm</sub>    |  | ---   | 3   | --- | A     |

**Notes:**

- 1: Repetitive rating, pulse width limited by maximum junction temperature.
- 2: Surface mounted on FR4 Board, t<sub>s</sub>≤10sec.
- 3: Pulse width ≤ 300μs, duty cycle ≤ 2%.

### 5 Typical characteristics diagrams

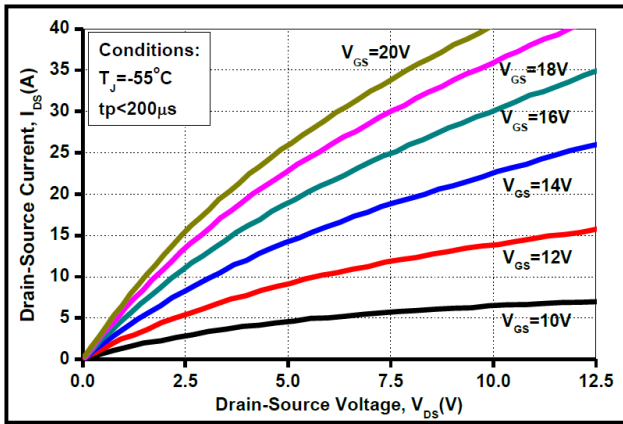

Figure 1. Output Characteristics  $T_J = -55^\circ\text{C}$

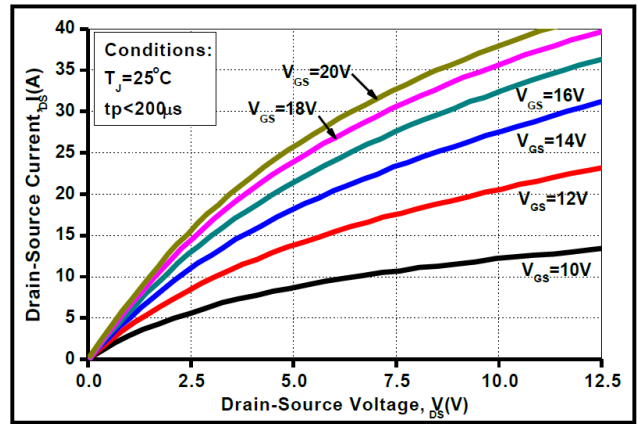

Figure 2. Output Characteristics  $T_J = 25^\circ\text{C}$

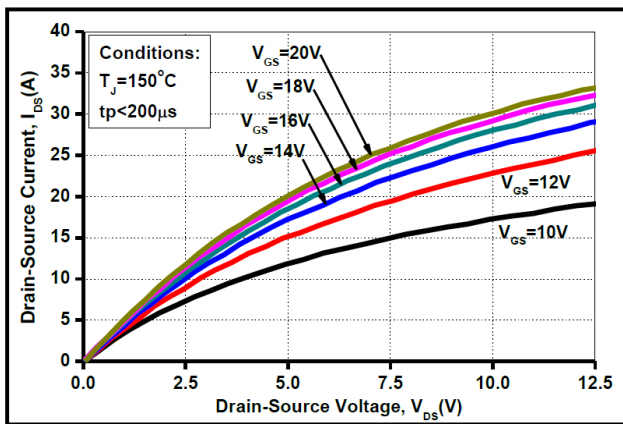

Figure 3. Output Characteristics  $T_J = 150^\circ\text{C}$

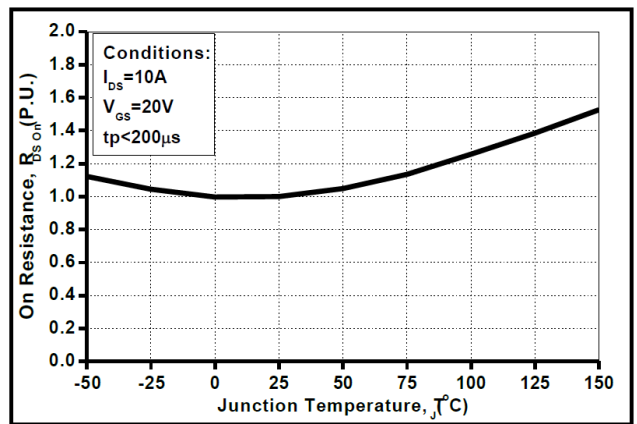

Figure 4. Normalized On-Resistance vs. Temperature

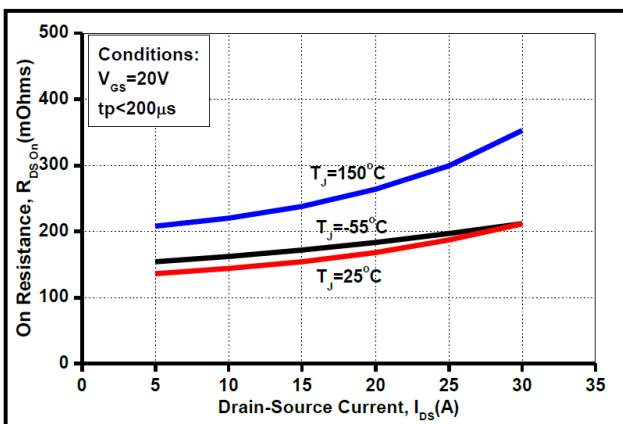

Figure 5. On-Resistance vs. Drain Current For Various Temperatures

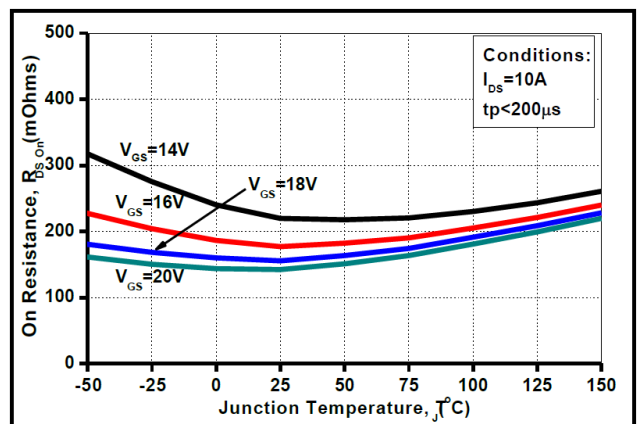

Figure 6. On-Resistance vs. Temperature For Various Gate Voltage

5 Typical characteristics diagrams(continues)

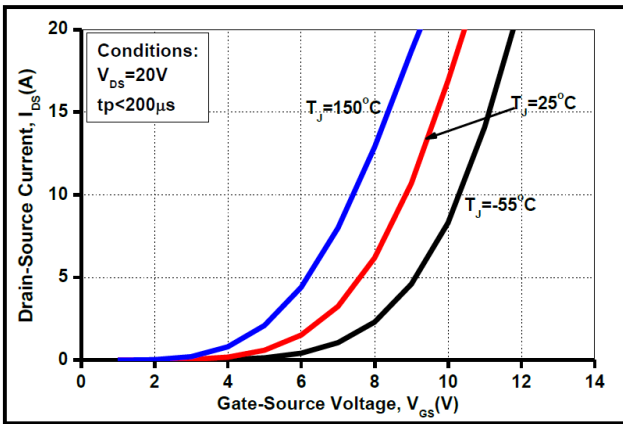

Figure 7. Transfer Characteristic for Various Junction Temperatures

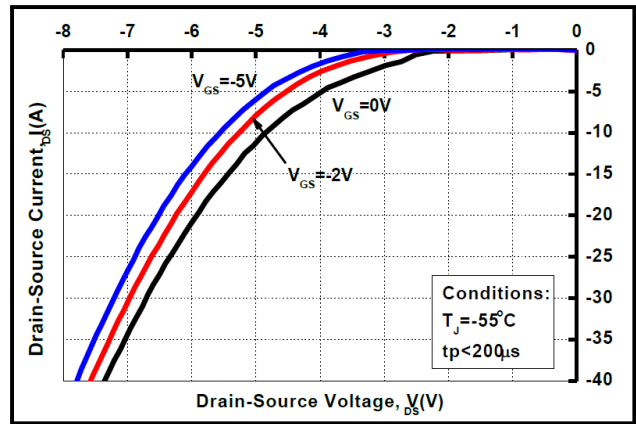

Figure 8. Body Diode Characteristic at -55 °C

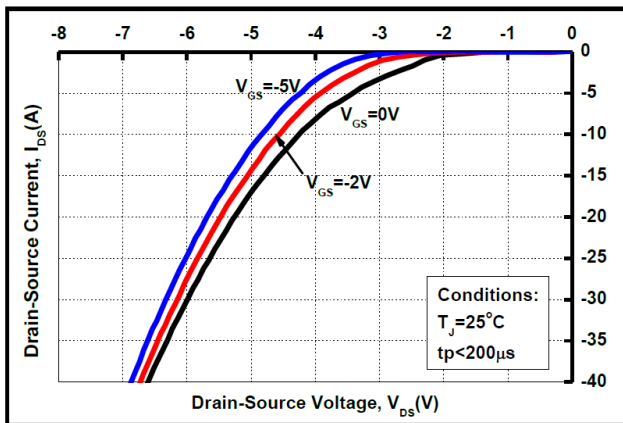

Figure 9. Body Diode Characteristic at 25 °C

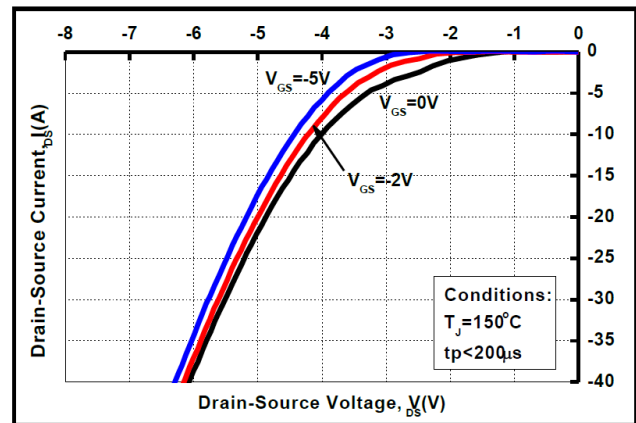

Figure 10. Body Diode Characteristic at 150 °C

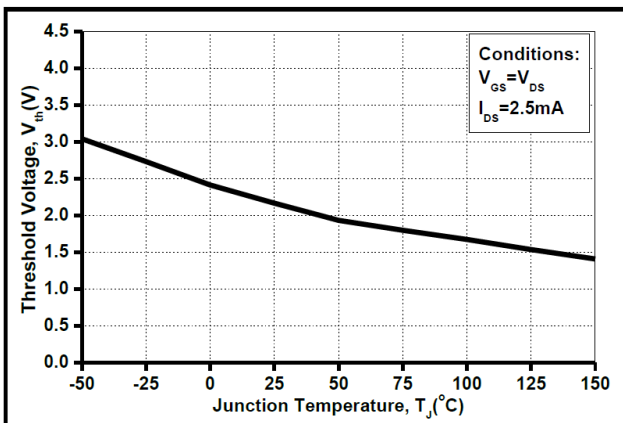

Figure 11. Threshold Voltage vs. Temperature

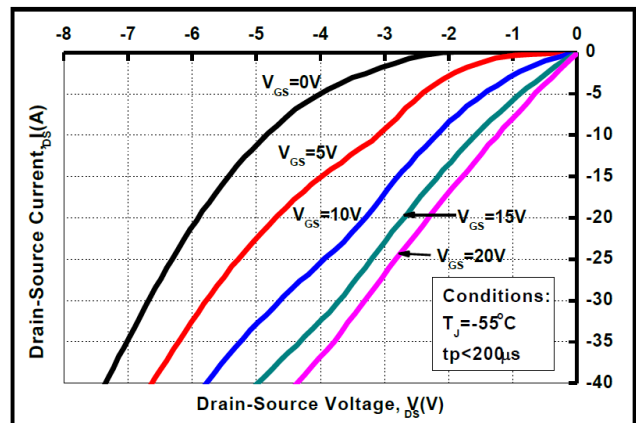

Figure 12. 3rd Quadrant Characteristic at -55 °C

### 5 Typical characteristics diagrams(continues)

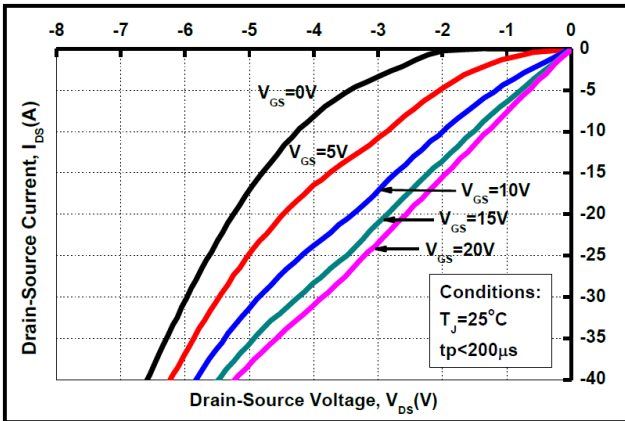

Figure 13. 3rd Quadrant Characteristic at 25 °C

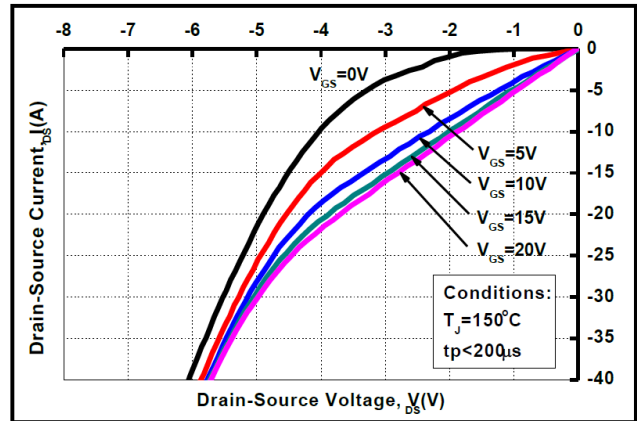

Figure 14. 3rd Quadrant Characteristic at 150 °C

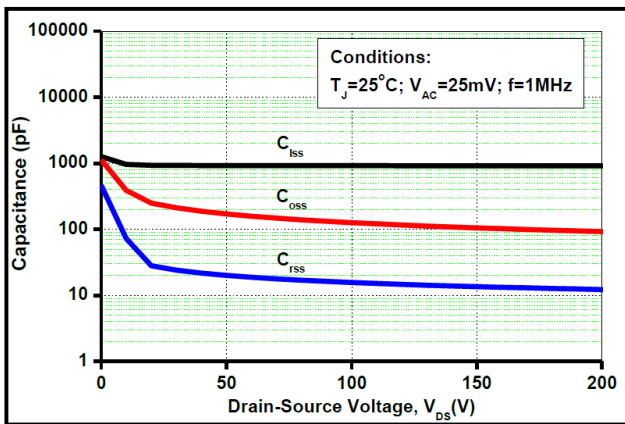

Figure 15. Capacitances vs. Drain-Source Voltage (0 - 200V)

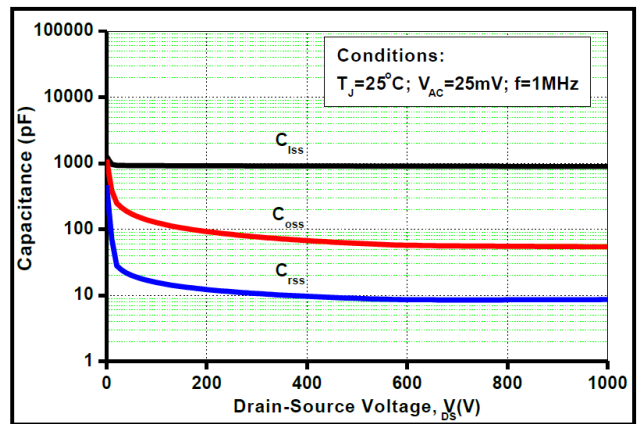

Figure 16. Capacitances vs. Drain-Source Voltage (0 - 1000V)

### 6 Product Specifications and Packaging Models

| Product Model | Package Type | Mark Name     | RoHS    | Package | Quantity |
|---------------|--------------|---------------|---------|---------|----------|
| DCC160M120G1  | TO-247-3L    | DCC160M120G1  | Pb-free | Tube    | 300/box  |
| DCCF160M120G1 | TO-247-4L    | DCCF160M120G1 | Pb-free | Tube    | 300/box  |

## 7 Dimensions

### TO-247-3L PACK OUTLINE DIMENSIONS

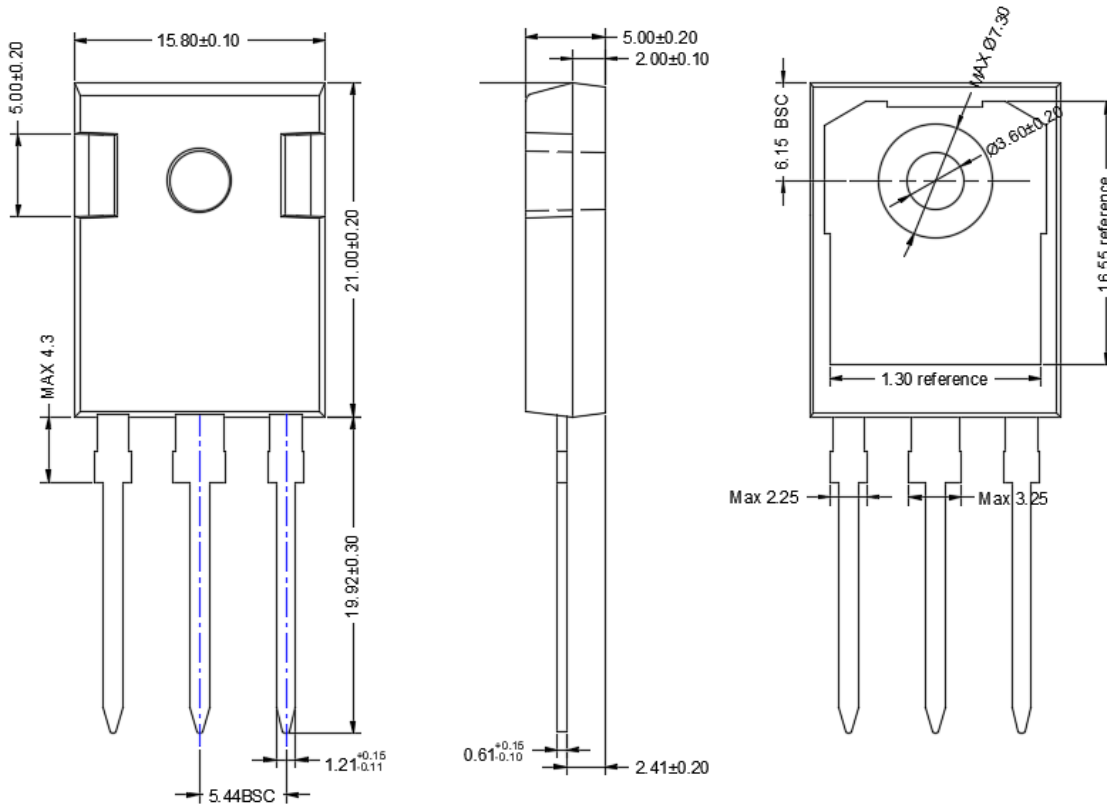

### TO-247-4L PACK OUTLINE DIMENSIONS

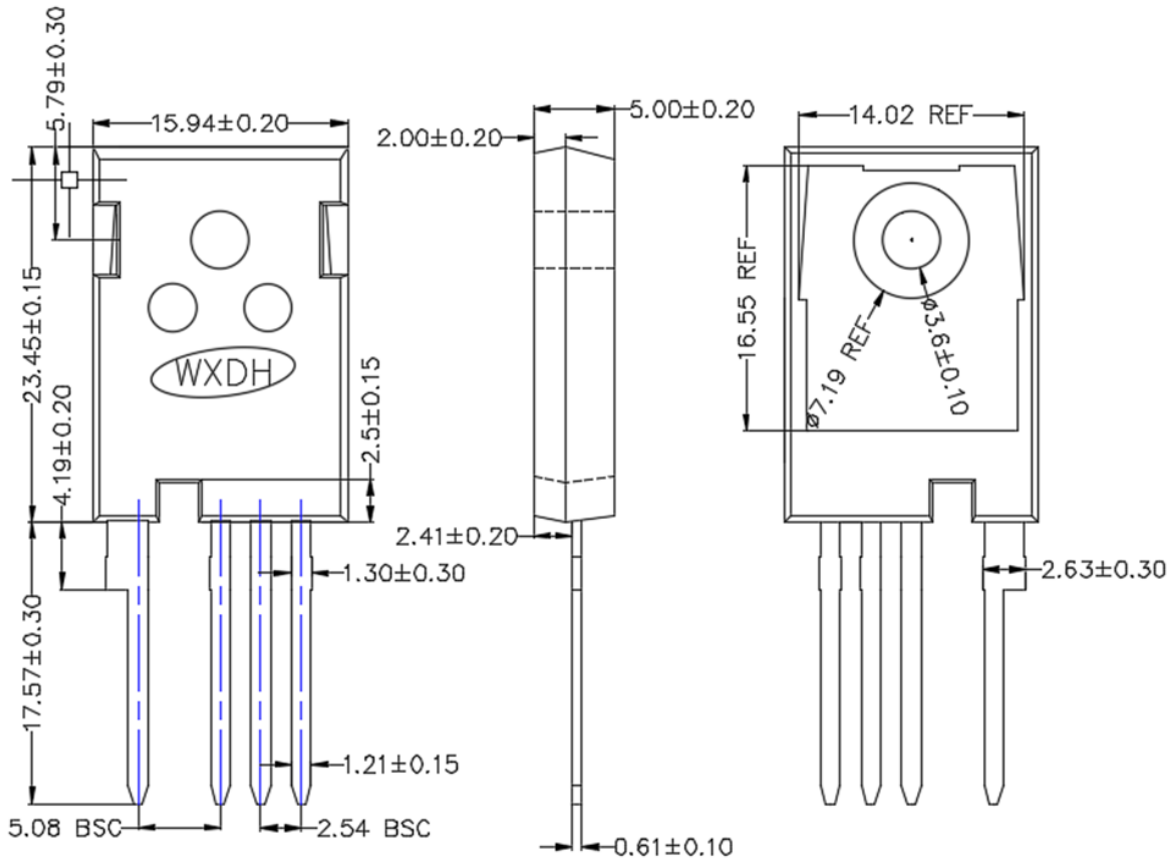

## 8 Attentions

- Jiangsu Donghai Semiconductor Technology CO.,LTD. reserves the right to change the specification without prior notice! The customer should obtain the latest version of the information before making the order and verify that the information is complete and up to date.
- It is the responsibility of the purchaser for any failure or failure of any semiconductor product under certain conditions. It is the responsibility of the purchaser to comply with safety standards and to take safety measures in the system design and machine manufacturing of Donghai products in order to avoid potential risk of failure. Injury or property damage.
- Product promotion is endless, our company will be dedicated to provide customers with better products.

## 9 Appendix

Revision history:

| Date       | REV. | Description | Page |
|------------|------|-------------|------|
| 2022.04.03 | 1.0  | Original    | 7    |