

Features

- **AEC-Q101 qualified**
- Low on resistance
- Low reverse transfer capacitances
- 100% single pulse avalanche energy test
- 100% ΔV_{DS} test
- Pb-Free plating / Halogen-Free / RoHS compliant

Key Parameters

V_{DS}	100V
$R_{DS(on)typ.}$	5.6mΩ
I_D	103A
V_{th}	1.7V
$C_{iss@10V}$	2690pF
Q_{gd}	12nC

Applications

- Motor Control and Drive
- Charge/Discharge for Battery Management System
- Synchronous Rectifier for SMPS
- Automotive application



TO-263

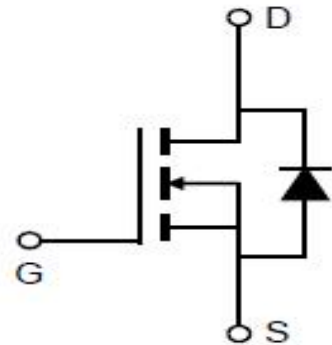
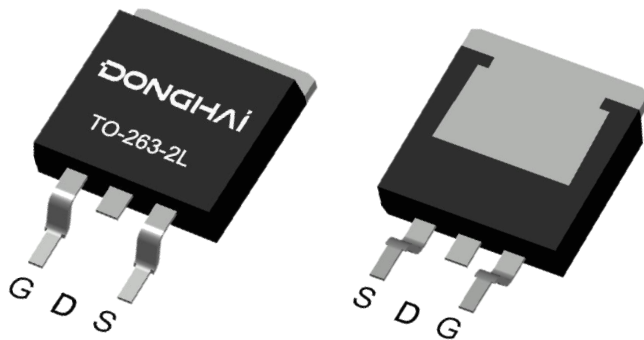

Marking & Packing Information

Part #	Package	Marking	Tube/Reel	Qty(pcs)
DSE065N10L3A	TO-263	DSE065N10L3A	Tape & Reel	800/box

Absolute Maximum Ratings

Parameter	Symbol	Value	Unit
Drain-source voltage	V_{DS}	100	V
Gate-Source voltage	V_{GS}	±20	V
Continuous drain current $T_C = 25^\circ\text{C}$ $T_C = 100^\circ\text{C}$	I_D	103 73	A
Pulsed drain current ($T_C = 25^\circ\text{C}$, t_p limited by T_{jmax})	$I_{D\ pulse}$	412	A
Avalanche energy, single pulse ($L=0.5\text{mH}$, $R_g=25\Omega$)	E_{AS}	324	mJ
Power dissipation $T_C = 25^\circ\text{C}$ $T_A = 25^\circ\text{C}$	P_{tot}	125	W
		2.0	W
Operating junction and storage temperature	T_j, T_{stg}	-55...+175	°C

Thermal Resistance

Parameter	Symbol	Max	Unit
Thermal resistance, junction – case.	R_{thJC}	1.20	°C/W
Thermal resistance, junction – ambient(min. footprint)	R_{thJA}	75	

Electrical Characteristic (at $T_j = 25^\circ\text{C}$, unless otherwise specified)

Static Characteristic

Parameter	Symbol	Value			Unit	Test Condition
		min.	typ.	max.		
Drain-source breakdown voltage	BV_{DSS}	100	-	-	V	$V_{GS}=0V, I_D=250\mu A$
Gate threshold voltage	$V_{GS(th)}$	1.2	1.7	2.2	V	$V_{DS}=V_{GS}, I_D=250\mu A$
Zero gate voltage drain current	I_{DSS}	-	-	1	μA	$V_{DS}=100V, V_{GS}=0V$ $T_j=25^\circ\text{C}$
		-	-	100		$T_j=125^\circ\text{C}$
Gate-source leakage current	I_{GSS}	-	-	100	nA	$V_{GS}=20V, V_{DS}=0V$
Drain-source on-state resistance	$R_{DS(on)}$	-	5.6	6.5	mΩ	$V_{GS}=10V, I_D=60A,$ $T_j=25^\circ\text{C}$
		-	7.2	9.5		$V_{GS}=4.5V, I_D=60A$

Dynamic Characteristic

Parameter	Symbol	Value			Unit	Test Condition
		min.	typ.	max.		
Input Capacitance	C_{iss}	-	2690	-	pF	$V_{GS}=0V, V_{DS}=50V, f=1MHz$
Output Capacitance	C_{oss}	-	713	-		
Reverse Transfer Capacitance	C_{rss}	-	47	-		
Gate Total Charge	Q_G	-	50	-	nC	$V_{GS}=10V, V_{DS}=50V, I_D=60A, f=1MHz$
Gate-Source charge	Q_{gs}	-	11	-		
Gate-Drain charge	Q_{gd}	-	12	-		
Turn-on delay time	$t_{d(on)}$	-	11	-	ns	$V_{GS}=10V, V_{DD}=50V, R_{G_ext}=3\Omega, I_D=60A$
Rise time	t_r	-	28	-		
Turn-off delay time	$t_{d(off)}$	-	37	-		
Fall time	t_f	-	15	-		

Body Diode Characteristic

Parameter	Symbol	Value			Unit	Test Condition
		min.	typ.	max.		
Diode Max Current	I_S		-	103	A	-
Diode Forward Voltage	V_{SD}	-	-	1.2	V	$V_{GS}=0V, I_{SD}=60A$
Diode Reverse Recovery Time	t_{rr}	-	55	-	ns	$T_j=25^\circ C, I_F=40A, dI/dt=100A/\mu s$
Diode Reverse Recovery Charge	Q_{rr}	-	90	-	nC	

Typical Characteristics Diagram

Fig1. Output Characteristics

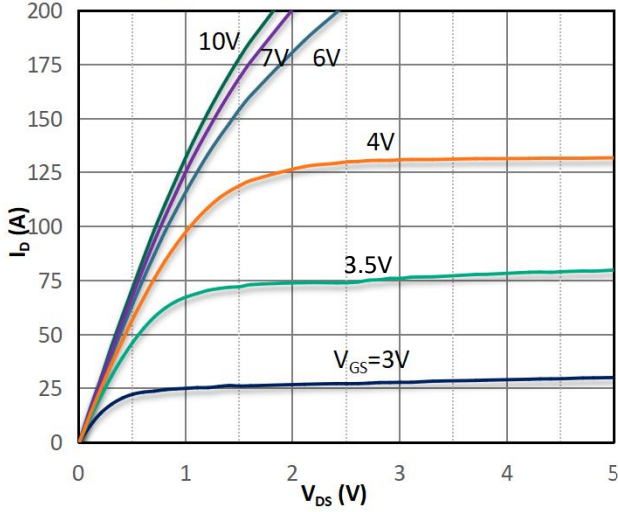

Fig2. Transfer Characteristics

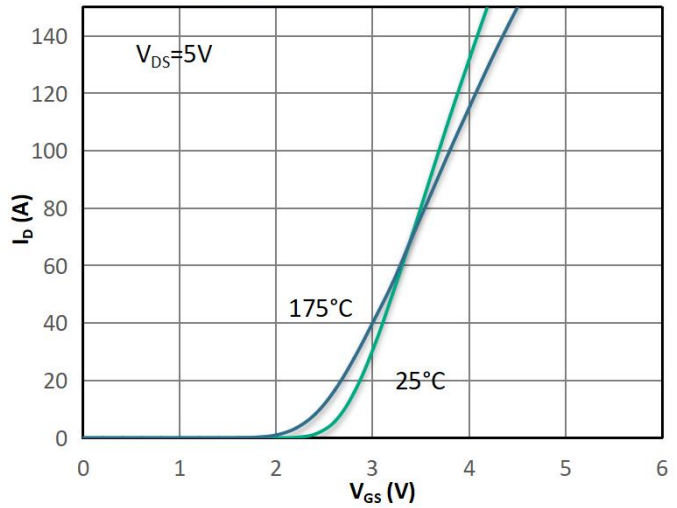

Fig3. Rds(on) vs Drain Current

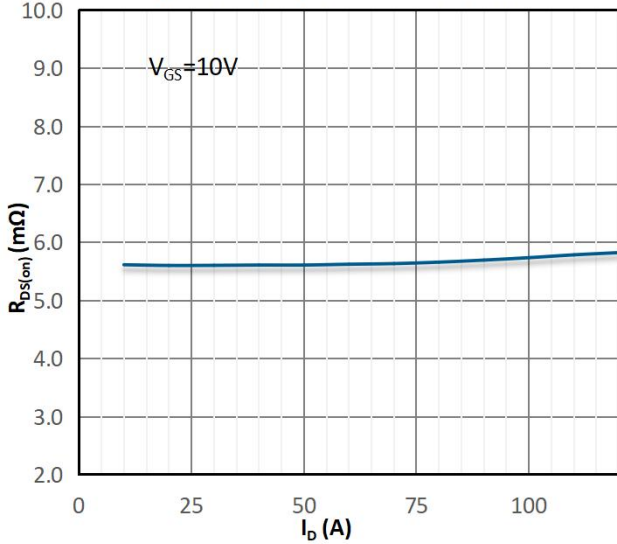

Fig 4. Rds(on) vs Gate Voltage

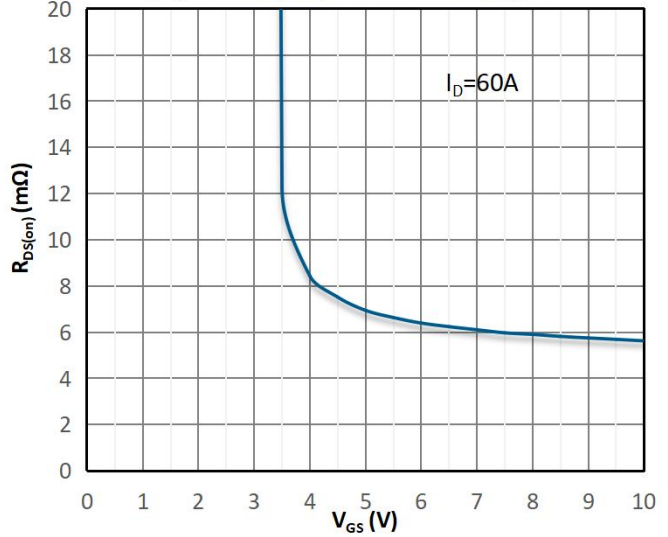

Fig5. Rds(on) vs. Temperature

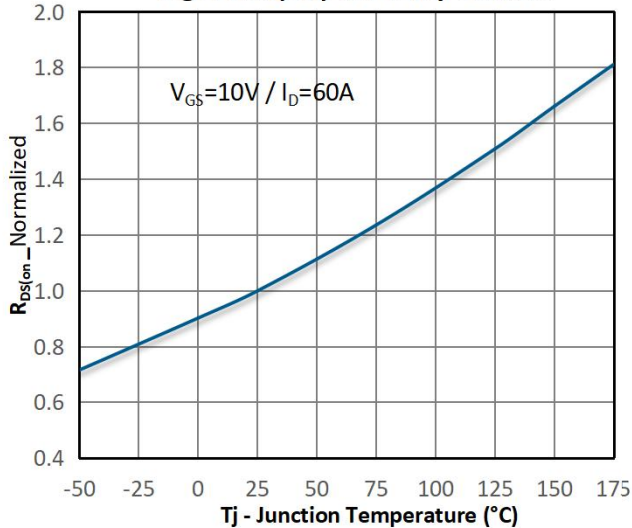
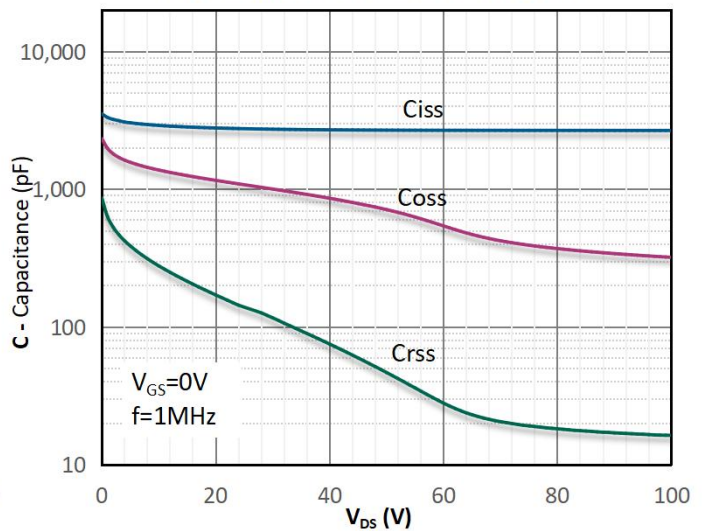
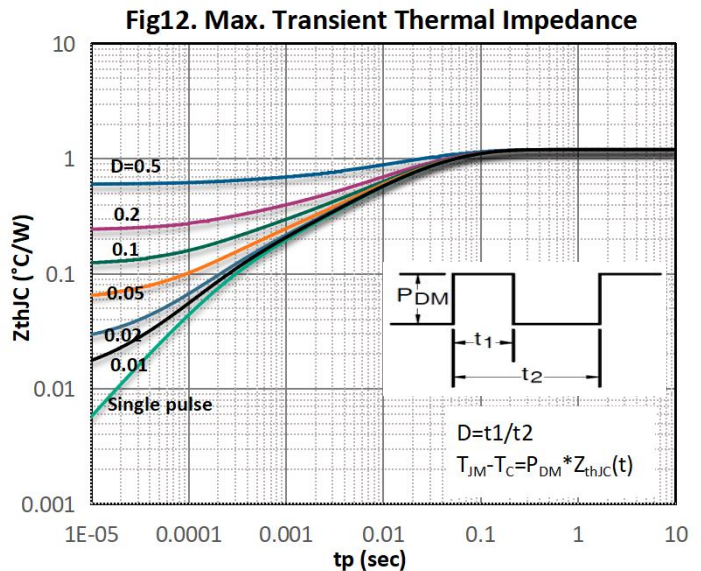
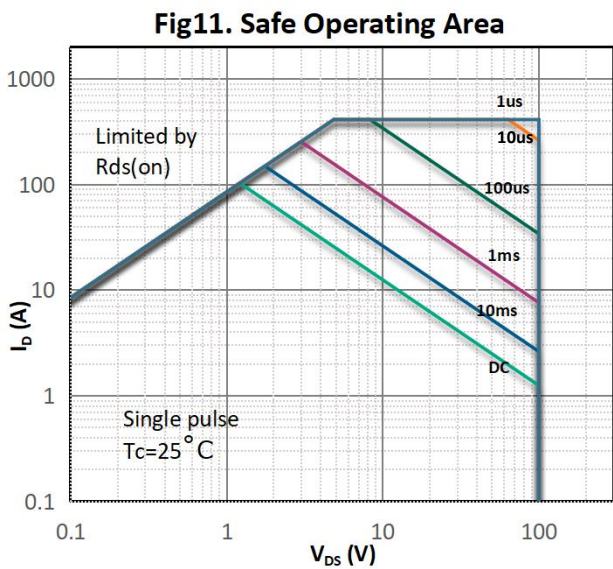
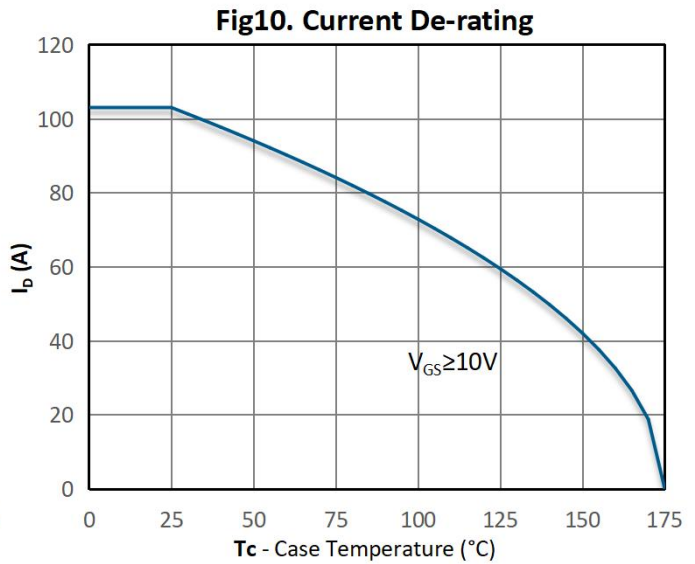
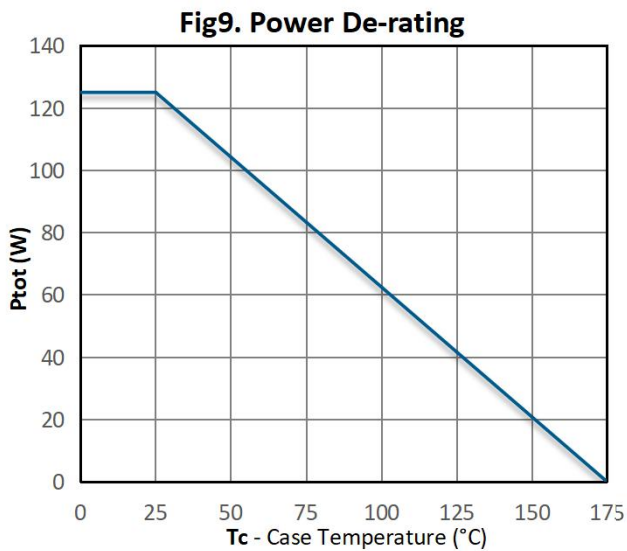
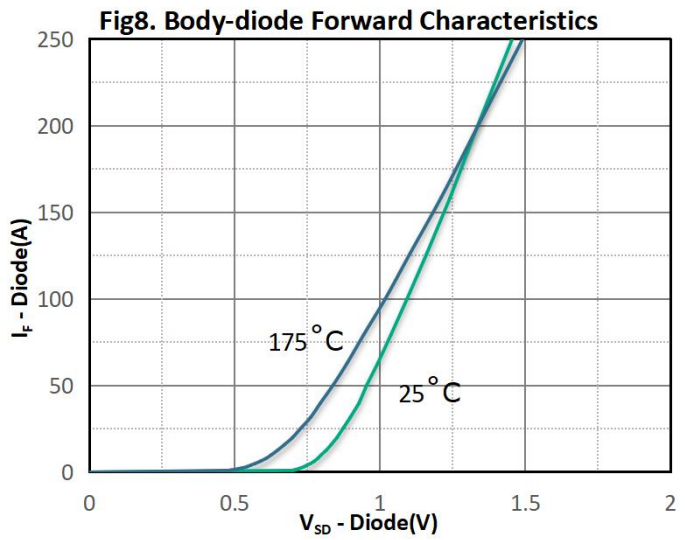
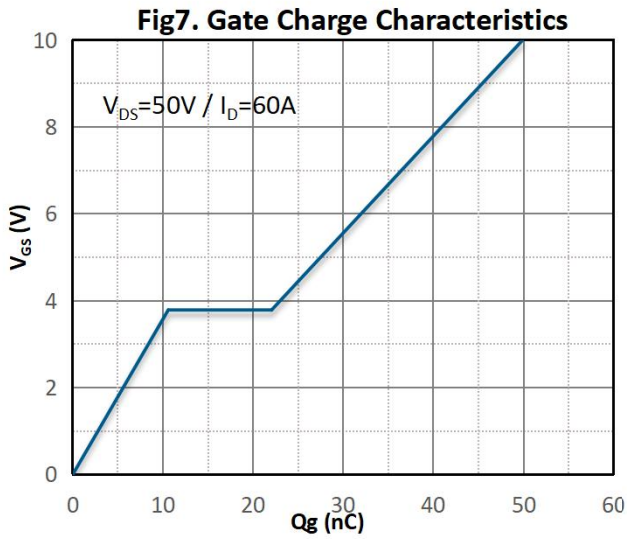

Fig6. Capacitance Characteristics



Typical Characteristics Diagram



Test Circuit & Waveform

Gate Charge Test Circuit & Waveform

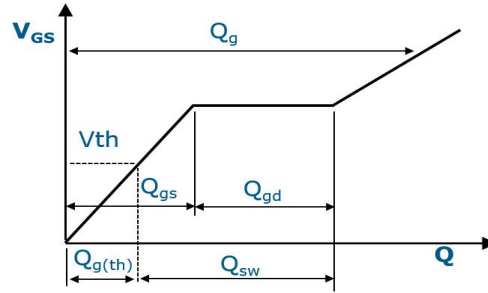
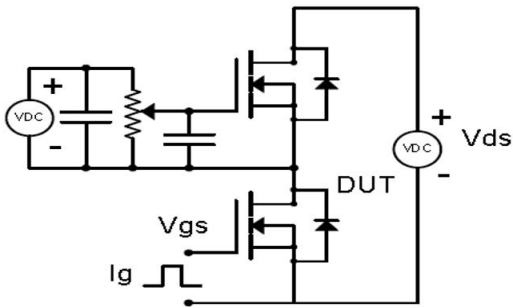

MOSFET Switching Test Circuit & Waveform

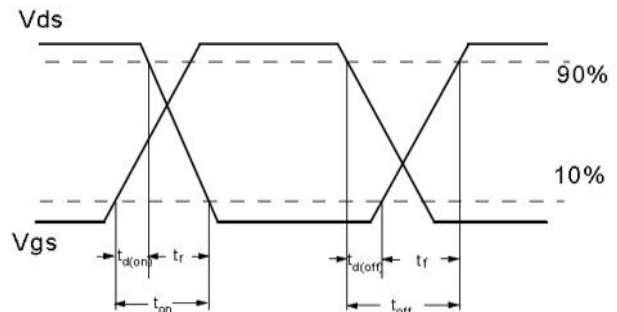
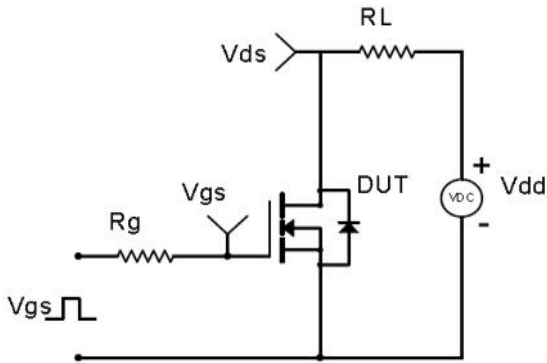

E_{AS} Test Circuit & Waveform

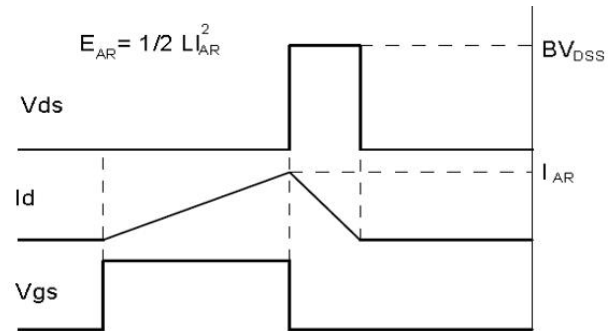
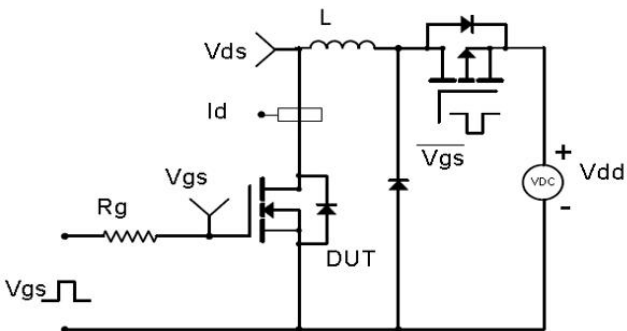

Diode Recovery Test Circuit & Waveform

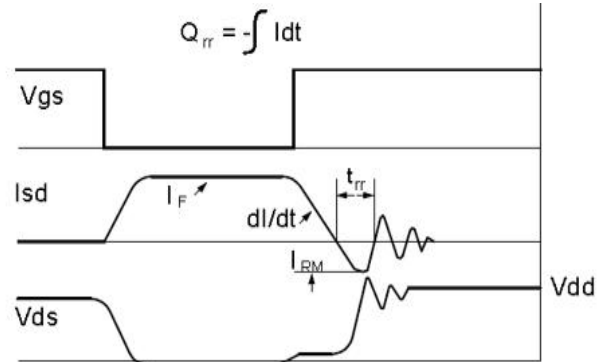
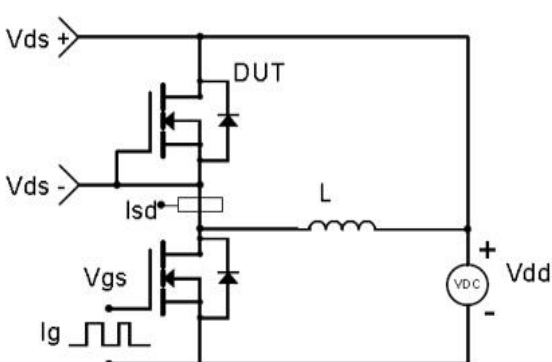

Package Outline : TO-263

*Dimensions in mm

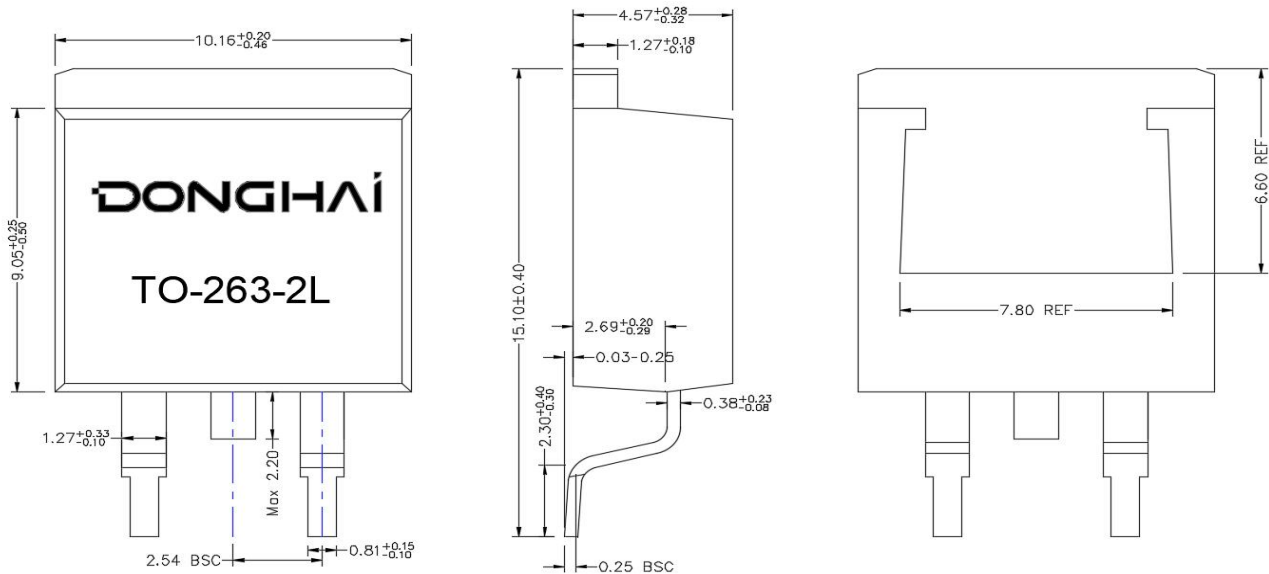

Revision History

Revison	Date	Major changes
1.0	2023/10/7	Release of formal version

Disclaimer

Unless otherwise specified in the datasheet, the product is designed and qualified as a standard commercial product and is not intended for use in applications that require extraordinary levels of quality and reliability, such as aviation, aerospace, life-support devices or systems.

Any and all semiconductor products have certain probability to fail or malfunction, which may result in personal injury, death or property damage. Customer are responsible for providing adequate safe measures when design their systems.

DONGHAI Semiconductor reserves the right to improve product design, function, reliability without notice. Copy Rights@Jiangsu Donghai Semiconductor Co. Ltd.