

120A 80V N-channel Enhancement Mode Power MOSFET

1 Description

This N-channel enhancement mode power mosfets used advanced splite gate trench technology design, provided excellent R_{DS(on)} and low gate charge. Which accords with the RoHS standard.

2 Features

- Fast switching
- Low on resistance
- Low gate charge
- High avalanche current
- Low reverse transfer capacitances
- 100% single pulse avalanche energy test
- 100% ΔV_{DS} test

3 Applications

- Synchronous rectification in SMPS
- Hard switching and high speed circuit
- Battery management
- UPS (Uninterruptible Power Supplies)
- Motor control and drive

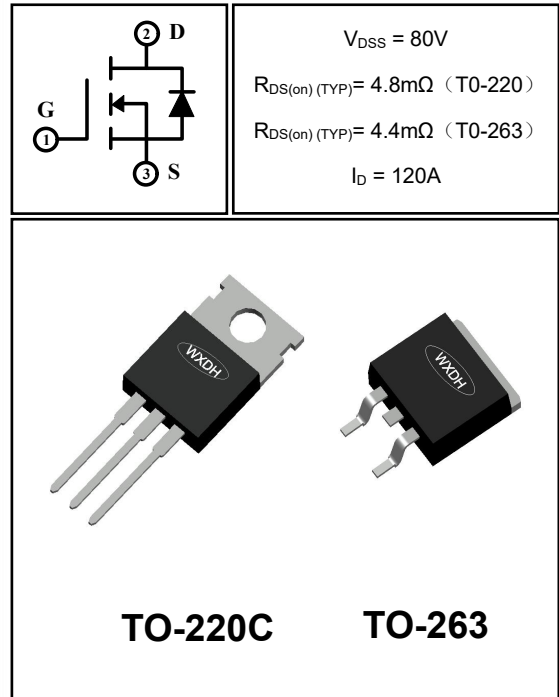

4 Electrical Characteristics

4.1 Absolute Maximum Ratings (T_c=25°C, unless otherwise noted)

| Parameter | | Symbol | Rating | Units |
|--|-----------------------|-----------|---------|-------|
| Drian-to-Source Voltage | | V_{DSS} | 80 | V |
| Gate-to-Source Voltage | | V_{GSS} | ±20 | V |
| Continuous Drain Current | T _C =25°C | I_D | 120 | A |
| | T _C =100°C | | 76 | A |
| Pulsed Drain Current ⁽¹⁾ | | I_{DM} | 480 | A |
| Single Pulse Avalanche Energy ⁽⁴⁾ | | E_{AS} | 576 | mJ |
| Power Dissipation | T _a =25°C | P_{tot} | 2.5 | W |
| | T _C =25°C | P_{tot} | 156 | W |
| Junction Temperature Range | | T_j | -55~150 | °C |
| Storage Temperature Range | | T_{stg} | -55~150 | °C |

4.2 Thermal Characteristics

| Parameter | Symbol | Value | | Units |
|---|------------|-------|-----|-------|
| | | Typ | Max | |
| Thermal Resistance, Junction to Case-sink | R_{thJC} | 0.8 | 1 | °C/W |
| Thermal Resistance, Junction to Ambient | R_{thJA} | 50 | 65 | °C/W |

4.3 Electrical Characteristics (Tc=25°C, unless otherwise noted)

| Parameter | Symbol | Test Condition | Value | | | Units |
|---|--------------------------|--|-------|------|-----------|------------|
| | | | Min | Typ | Max | |
| Off Characteristics | | | | | | |
| Drain-to-Source Breakdown Voltage | BV_{DSS} | $I_D=250\mu A, V_{GS}=0V$ | 80 | -- | -- | V |
| Drain-to-Source Leakage Current | I_{DSS} | $V_{DS}=80V, V_{GS}=0V, T_C=25^\circ C$ | -- | -- | 1 | μA |
| | | $V_{DS}=80V, V_{GS}=0V, T_C=125^\circ C$ | -- | -- | 100 | μA |
| Gate-to-Source Leakage Current | I_{GSS} | $V_{GS}=\pm 20V, V_{DS}=0V$ | -- | -- | ± 100 | nA |
| On Characteristics | | | | | | |
| Gate Threshold Voltage | $V_{GS(th)}$ | $V_{DS}=V_{GS}, I_D=250\mu A$ | 2 | 3 | 4 | V |
| Drain-to-Source on-state Resistance | $R_{DS(on)}$ (TO-220) | $V_{GS}=10V, I_D=80A$ | -- | 4.8 | 5.3 | m Ω |
| | $R_{DS(on)}$ (TO-263) | $V_{GS}=10V, I_D=80A$ | -- | 4.4 | 5.1 | m Ω |
| Transconductance | Gfs | $V_{DS}=5V, I_D=80A$ | -- | 100 | -- | S |
| Dynamic Characteristics | | | | | | |
| Input Capacitance | C_{iss} | $V_{GS}=0V, V_{DS}=50V, f=1.0MHz$ | -- | 3656 | -- | pF |
| Output Capacitance | C_{oss} | | -- | 651 | -- | |
| Reverse Transfer Capacitance | C_{rss} | | -- | 19 | -- | |
| Gate Resisitance | R_G | $V_{DD}=0V, V_{GS}=0V, F=1MHz$ | -- | 2.5 | -- | Ω |
| Switching Characteristics | | | | | | |
| Turn-on Delay Time | $t_{d(on)}$ | $V_{gs}=10V, V_{ds}=40V, I_d=60A, R_g=3\Omega$ | -- | 18 | -- | nS |
| Turn-on Rise Time | t_r | | -- | 44 | -- | |
| Turn-off Delay Time | $t_{d(off)}$ | | -- | 34 | -- | |
| Turn-off Fall Time | t_f | | -- | 17 | -- | |
| Total Gate Charge | Q_g | $I_D=60A, V_{DD}=50V, V_{GS}=10V$ | -- | 48 | -- | nC |
| Gate-to-Source Charge | Q_{gs} | | -- | 20 | -- | |
| Gate-to-Drain("Miller") Charge | Q_{gd} | | -- | 8 | -- | |
| Gate plateau voltage | $V_{plateau}$ | | -- | 5.4 | -- | |
| Drain-Source Diode Characteristics | | | | | | |
| Diode Forward Voltage ⁽³⁾ | V_{SD} | $V_{GS}=0V, I_S=60A$ | -- | -- | 1.2 | V |
| Diode Forward Current | I_S | | -- | -- | 120 | A |
| Reverse Recovery Time ⁽³⁾ | t_{rr} | $T_J=25^\circ C, I_F=30A, di_F/dt=100A/\mu s, V_{GS}=0V$ | -- | 40 | -- | nS |
| Reverse Recovery Charge ⁽³⁾ | Q_{rr} | | -- | 35 | -- | nC |

Notes:

- 1: Repetitive rating, pulse width limited by maximum junction temperature.
- 2: Surface mounted on FR4 Board, $t \leq 10sec$.
- 3: Pulse width $\leq 300\mu s$, duty cycle $\leq 2\%$.
- 4: $L=0.5mH, V_{DD}=50V, V_G=10V, Start T_J=25^\circ C$.

5 Typical characteristics diagrams

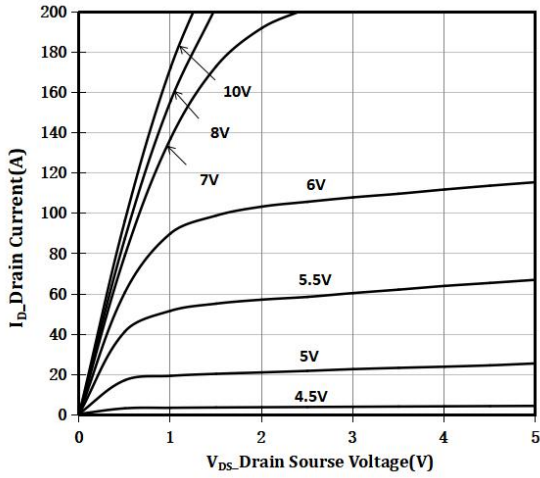

Fig 1. Output Characteristics

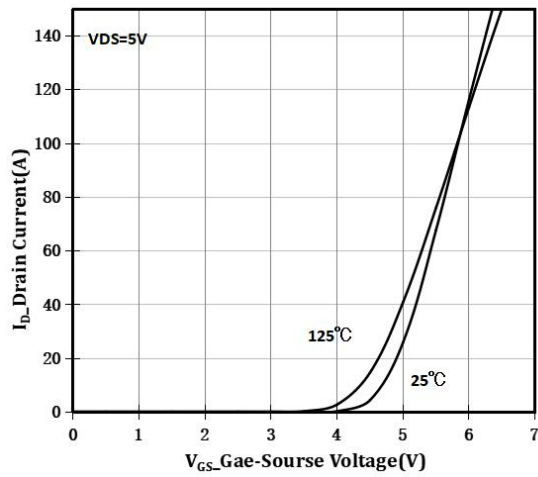

Fig 2. Transfer Characteristics

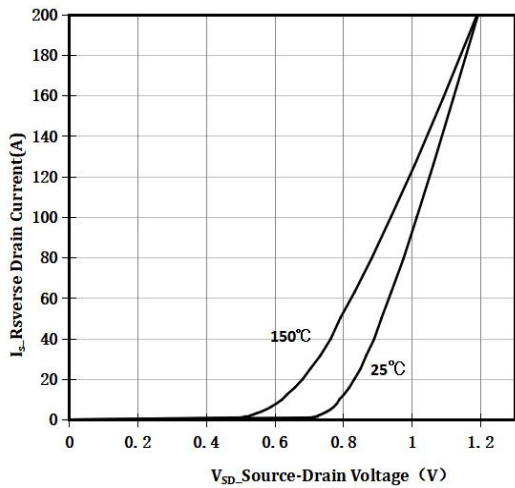

Figure 3 Source-Drain Diode Forward

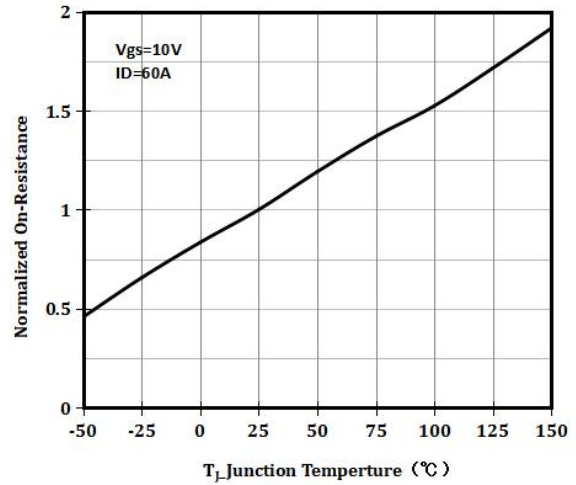

Fig 4. Rds(on) vs. Temperature

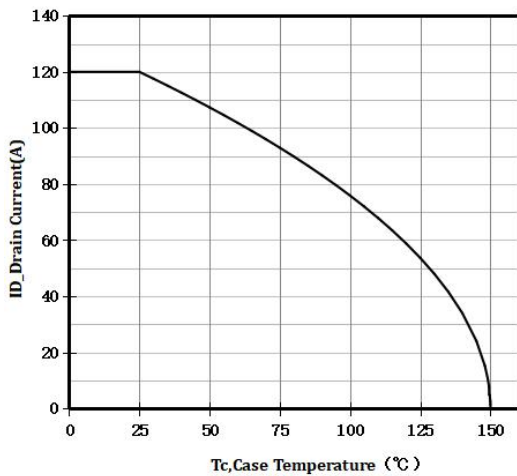

Figure 5. ID Current Derating

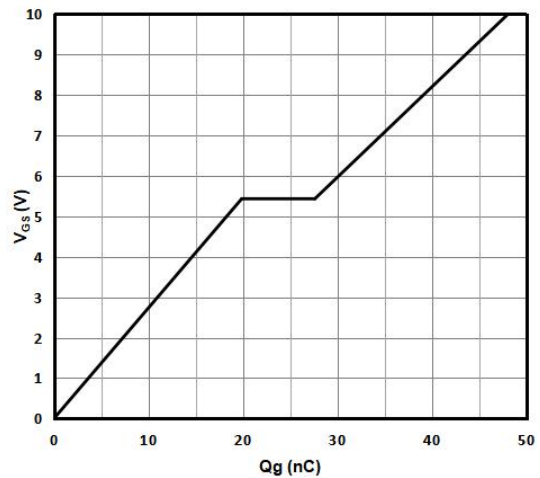

Figure 6. Gate Charge Characteristics

5 Typical characteristics diagrams(continues)

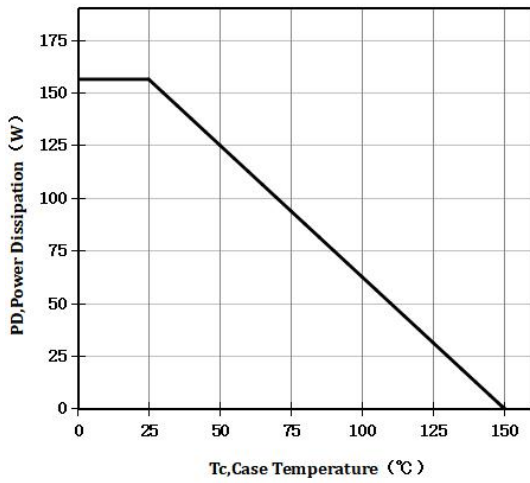

Figure 7. Power Dissipation

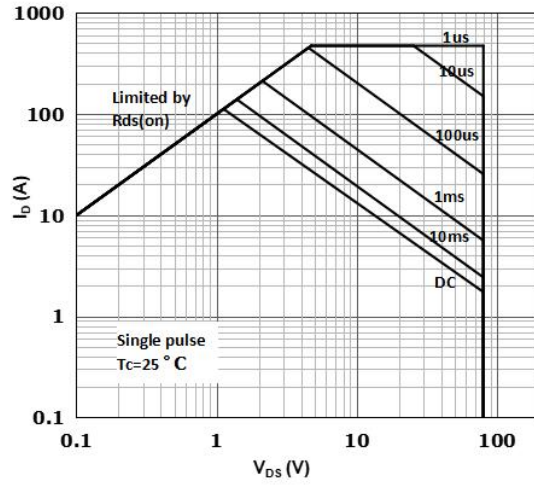

Figure 8. Safe Operating Area

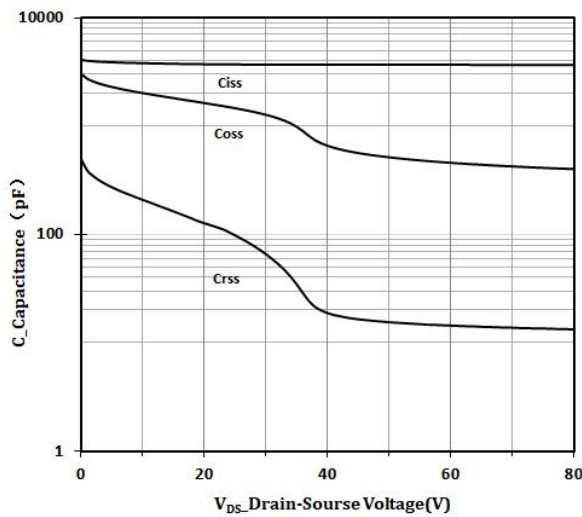

Figure 9. Capacitance Characteristics

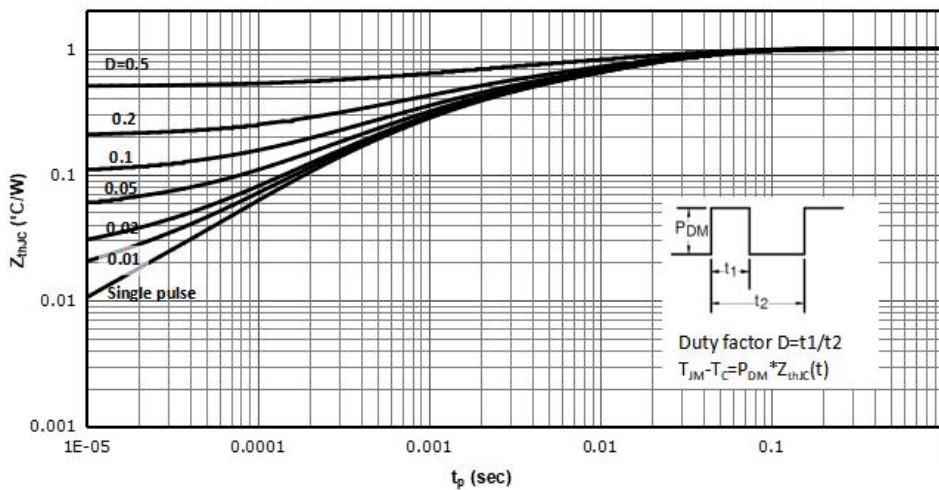
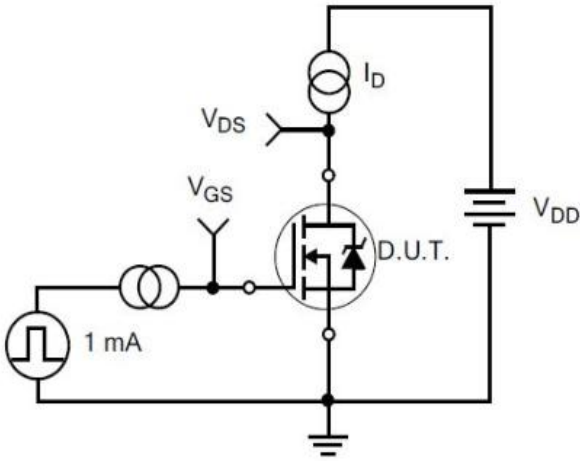
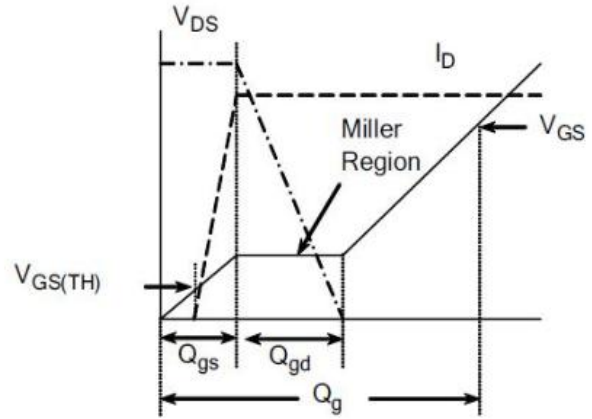

Figure 10. Normalized Maximum Transient Thermal Impedance

6 Typical Test Circuit and Waveform



1) Gate Charge Test Circuit



2) . Gate Charge Waveform

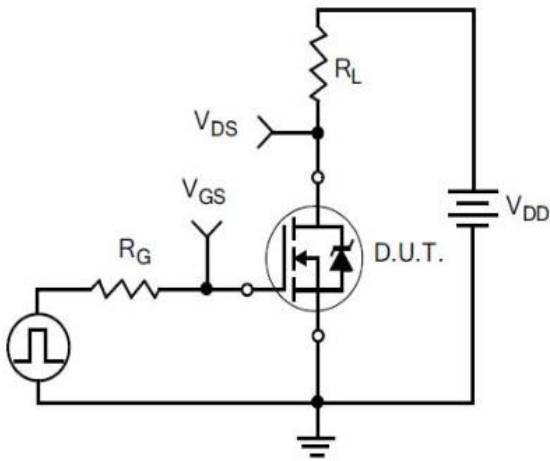

3) Resistive Switching Test Circuit

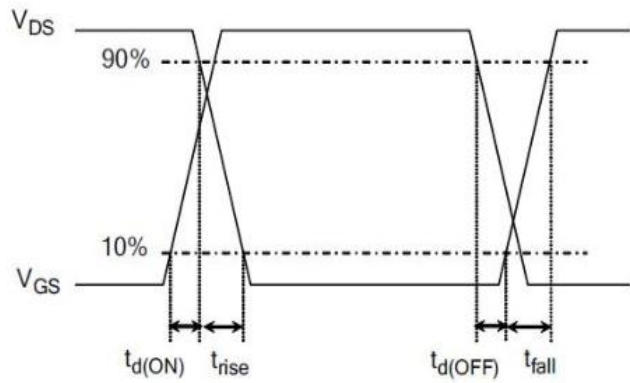

4) Resistive Switching Waveforms

6 Typical Test Circuit and Waveform(continues)

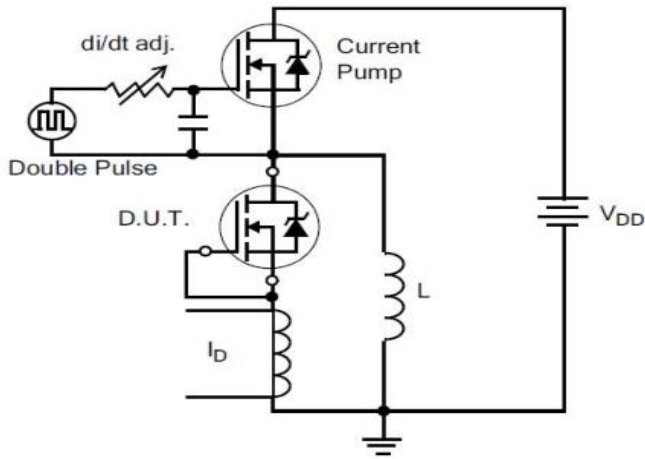

5) Diode Reverse Recovery Test Circuit

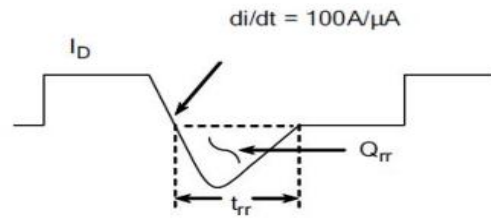

6) Diode Reverse Recovery Waveform

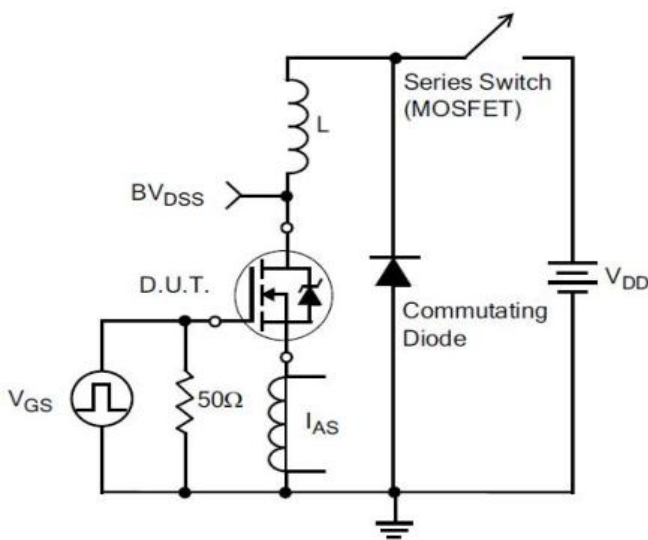

7) . Unclamped Inductive Switching Test Circuit

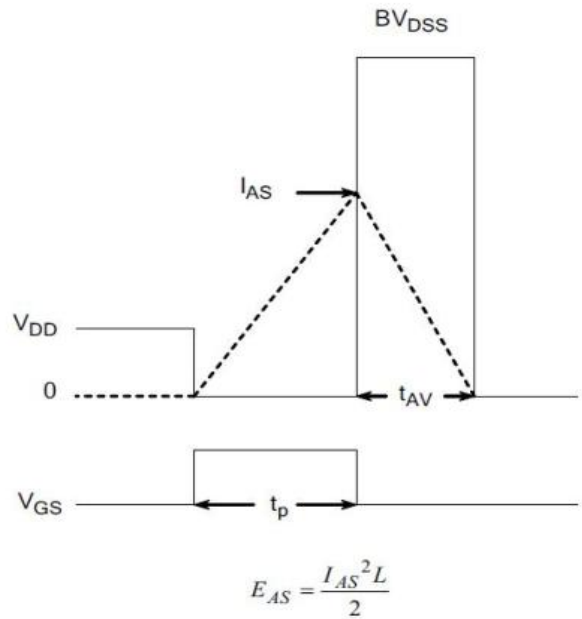

8) Unclamped Inductive Switching Waveforms

7 Product Names Rules

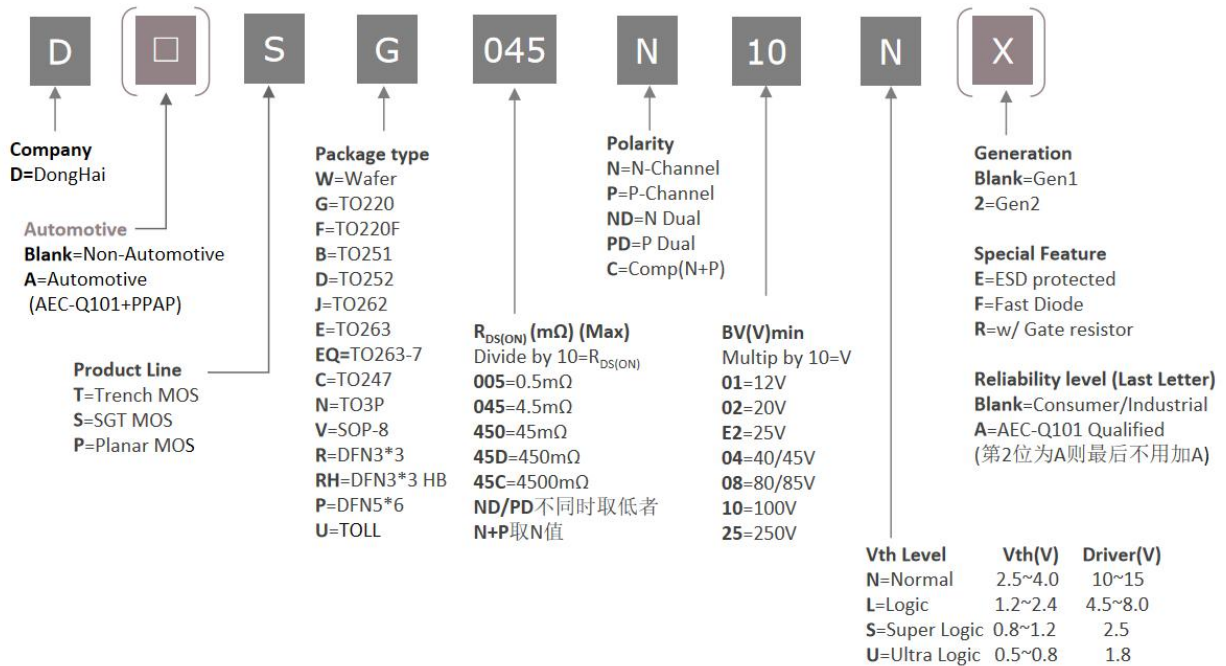

8 Product Specifications and Packaging Models

| Product Model | Package Type | Mark Name | RoHS | Package | Quantity |
|---------------|--------------|-------------|---------|-------------|----------|
| DSG053N08N3 | TO-220 | DSG053N08N3 | Pb-free | Tube | 1000/box |
| DSE051N08N3 | TO-263 | DSE051N08N3 | Pb-free | Tape & Reel | 800/box |

9 Dimensions

TO-220C PACKAGE OUTLINE DIMENSIONS

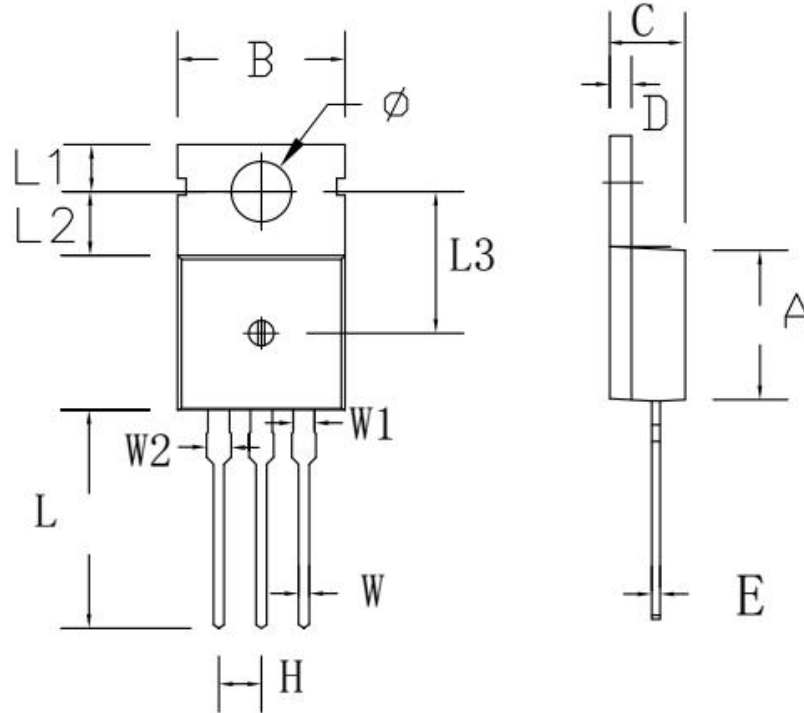

| Symbol | Dimensions In Millimeters | | Dimensions In Inches | |
|--------|---------------------------|-------|----------------------|-------|
| | min. | max. | min. | max. |
| A | 8.80 | 9.30 | 0.346 | 0.366 |
| B | 9.70 | 10.30 | 0.382 | 0.406 |
| C | 4.25 | 4.75 | 0.167 | 0.187 |
| D | 1.20 | 1.45 | 0.047 | 0.057 |
| E | 0.40 | 0.60 | 0.016 | 0.024 |
| H | 2.54 TYP | | 0.100 TYP | |
| W | 0.60 | 0.95 | 0.024 | 0.037 |
| W1 | 1.05 | 1.45 | 0.041 | 0.057 |
| W2 | 1.20 | 1.60 | 0.047 | 0.063 |
| L | 12.60 | 13.40 | 0.496 | 0.528 |
| L1 | 2.45 | 2.95 | 0.096 | 0.116 |
| L2 | 3.45 | 3.95 | 0.136 | 0.156 |
| L3 | 8.15 | 8.65 | 0.321 | 0.341 |
| Φ | 3.50 | 3.90 | 0.138 | 0.154 |

9 Dimensions(continues)

TO-263 PACKAGE OUTLINE DIMENSIONS

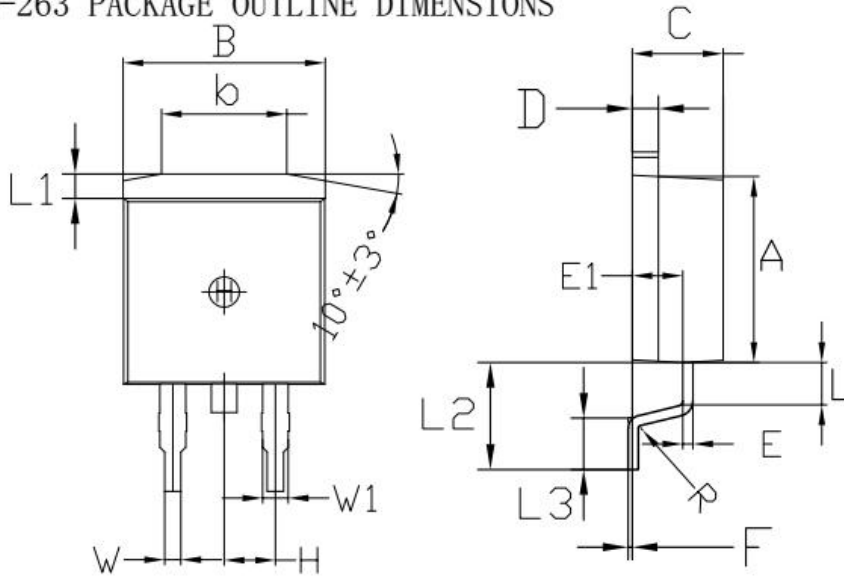

| Symbol | Dimensions In Millimeters | | Dimensions In Inches | |
|--------|---------------------------|-------|----------------------|--------|
| | min. | max. | min. | max. |
| A | 8.80 | 9.30 | 0.346 | 0.366 |
| B | 9.70 | 10.30 | 0.382 | 0.406 |
| C | 4.25 | 4.75 | 0.167 | 0.187 |
| D | 1.20 | 1.45 | 0.047 | 0.057 |
| E | 0.40 | 0.60 | 0.016 | 0.024 |
| L | 1.90 | 2.30 | 0.075 | 0.091 |
| L1 | 1.15 | 1.45 | 0.045 | 0.057 |
| R | 0.24 | 0.26 | 0.0095 | 0.0102 |
| W | 0.80 | 0.82 | 0.0315 | 0.0323 |
| W1 | 1.20 | 1.30 | 0.047 | 0.051 |
| H | 2.54 TYP | | 0.200 TYP | |
| b | 5.50 | 6.50 | 0.216 | 0.256 |
| E1 | 2.4 | 2.6 | 0.0946 | 0.1024 |
| L2 | 5.20 | 5.80 | 0.205 | 0.228 |
| L3 | 2.20 | 3.20 | 0.087 | 0.126 |
| F | 0.03 | 0.23 | 0.0012 | 0.0091 |

10 Attentions

- Jiangsu Donghai Semiconductor Technology CO.,LTD. reserves the right to change the specification without prior notice! The customer should obtain the latest version of the information before making the order and verify that the information is complete and up to date.
- It is the responsibility of the purchaser for any failure or failure of any semiconductor product under certain conditions. It is the responsibility of the purchaser to comply with safety standards and to take safety measures in the system design and machine manufacturing of Donghai products in order to avoid potential risk of failure. Injury or property damage.
- Product promotion is endless, our company will be dedicated to provide customers with better products.

11 Appendix

Revision history:

| Date | REV. | Description | Page |
|------------|------|-------------|------|
| 2022.08.10 | 1.0 | Original | 10 |