

170A 85V N-channel Enhancement Mode Power MOSFET

1 Description

These N-channel enhancement mode power mosfets used advanced splite gate trench technology design, provided excellent Rdson and low gate charge. Which accords with the RoHS standard.

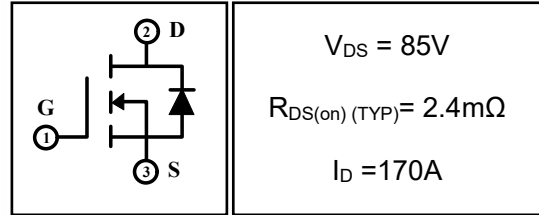

2 Features

- **AEC-Q101 qualified**
- Fast switching
- Low on resistance
- Low gate charge
- High avalanche current
- Low reverse transfer capacitances
- 100% single pulse avalanche energy test
- 100% ΔV_{DS} test

3 Applications

- Synchronous rectification in SMPS
- Hard switching and high speed circuit
- Power tools
- UPS
- Motor control

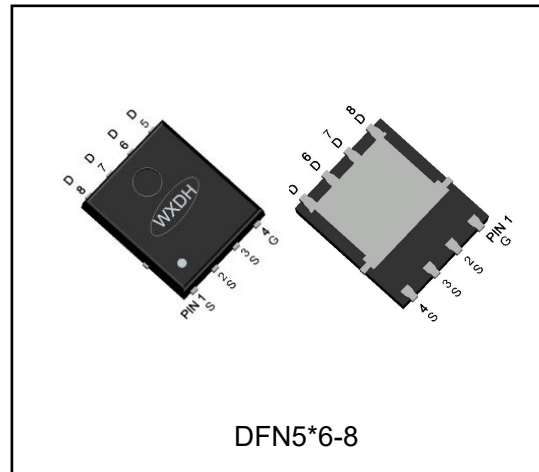

4 Electrical Characteristics

4.1 Absolute Maximum Ratings (Tc=25°C, unless otherwise noted)

Parameter		Symbol	Rating	Units
Drian-to-Source Voltage		V_{DSS}	85	V
Gate-to-Source Voltage		V_{GSS}	± 20	V
Continuous Drain Current	$T_C = 25^\circ C$	I_D	170	A
	$T_C = 100^\circ C$		120	A
Pulsed Drain Current ⁽¹⁾		I_{DM}	680	A
Single Pulse Avalanche Energy ⁽⁴⁾		E_{AS}	841	mJ
Power Dissipation	$T_a = 25^\circ C$	P_{tot}	2.7	W
	$T_C = 25^\circ C$	P_{tot}	167	W
Junction Temperature Range		T_j	-55 ~ 175	°C
Storage Temperature Range		T_{stg}	-55 ~ 175	°C

4.2 Thermal Characteristics

Parameter	Symbol	Value		Units
		Typ	Max	
Thermal Resistance, Junction to Case-sink	R_{thJC}	--	0.9	°C/W
Thermal Resistance, Junction to Ambient	R_{thJA}	--	55	°C/W

4.3 Electrical Characteristics (T_c=25°C, unless otherwise noted)

Parameter	Symbol	Test Condition	Value			Units
			Min	Typ	Max	
Off Characteristics						
Drain-to-Source Breakdown Voltage	BV _{DSS}	I _D =250μA, V _{GS} =0V	85	--	--	V
Drain-to-Source Leakage Current	I _{DSS}	V _{DS} =85V, V _{GS} =0V, T _C =25°C	--	--	1	μA
		V _{DS} =85V, V _{GS} =0V, T _C =125°C	--	--	100	μA
Gate-to-Source Leakage Current	I _{GSS}	V _{GS} =±20V, V _{DS} =0V	--	--	±100	nA
On Characteristics						
Gate Threshold Voltage	V _{GS(th)}	V _{DS} =V _{GS} , I _D =250μA	2	3	4	V
Drain-to-Source on-state Resistance	R _{DS(on)}	V _{GS} =10V, I _D =80A	--	2.4	2.9	mΩ
Dynamic Characteristics						
Input Capacitance	C _{iss}	V _{GS} =0V, V _{DS} =40V, f=1.0MHz	--	5621	--	pF
Output Capacitance	C _{oss}		--	923	--	
Reverse Transfer Capacitance	C _{rss}		--	10	--	
Gate Resisitance	R _G	V _{DD} =0V, V _{GS} =0V, F=1MHz	--	3	--	Ω
Switching Characteristics						
Turn-on Delay Time	t _{d(on)}	I _D =80A, V _{DD} =40V, V _{GS} =10V, R _{GEN} =3Ω	--	26	--	nS
Turn-on Rise Time	t _r		--	67	--	
Turn-off Delay Time	t _{d(off)}		--	63	--	
Turn-off Fall Time	t _f		--	37	--	
Total Gate Charge	Q _g	I _D =80A, V _{DD} =40V, V _{GS} =10V	--	85	--	nC
Gate-to-Source Charge	Q _{gs}		--	35	--	
Gate-to-Drain("Miller") Charge	Q _{gd}		--	18	--	
Drain-Source Diode Characteristics						
Diode Forward Voltage ⁽³⁾	V _{SD}	V _{GS} =0V, I _S =50A	--	--	1.2	V
Diode Forward Current	I _S		--	--	170	A
Reverse Recovery Time ⁽³⁾	t _{rr}	T _J =25°C, I _F =50A, di _F /dt=100A/μS, V _{GS} =0V	--	79	--	nS
Reverse Recovery Charge ⁽³⁾	Q _{rr}		--	110	--	nC

Notes:

- 1: Repetitive rating, pulse width limited by maximum junction temperature.
- 2: Surface mounted on FR4 Board, t_s≤10sec.
- 3: Pulse width ≤ 300μs, duty cycle ≤ 2%.
- 4: L=0.5mH, V_{DD}=50V, V_{GATE}=85V, Start T_J=25°C.

5 Typical characteristics diagrams

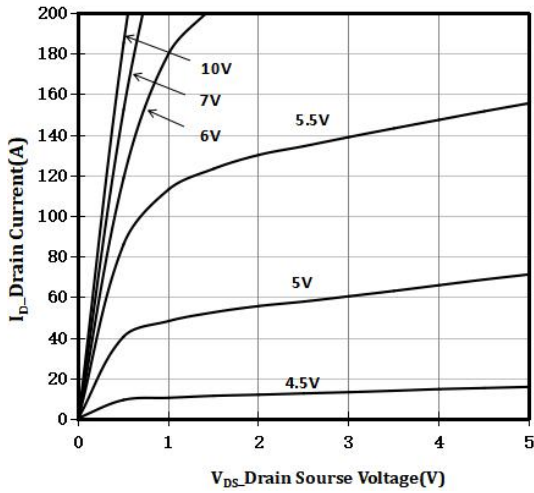

Figure 1 Output Characteristics

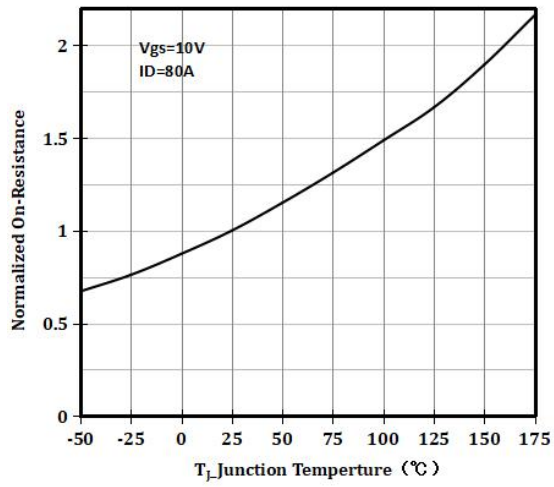

Figure 2 R_{ds(on)}-Junction Temperature

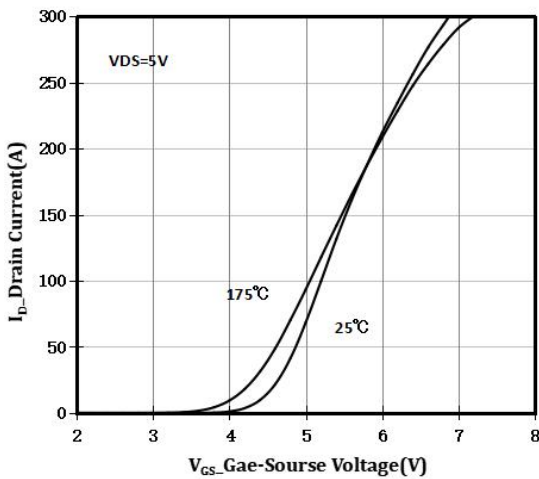

Figure 3 Transfer Characteristics

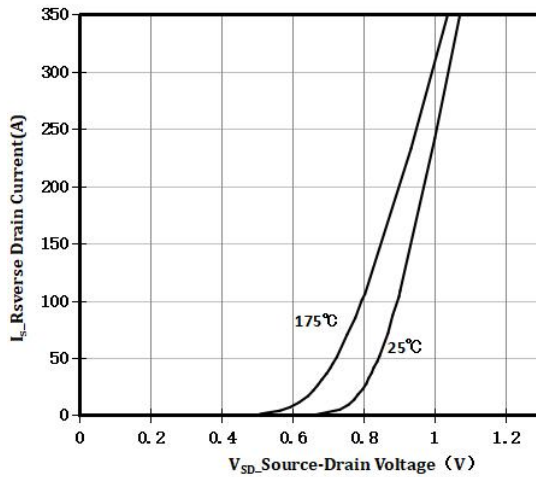

Figure 4 Source-Drain Diode Forward

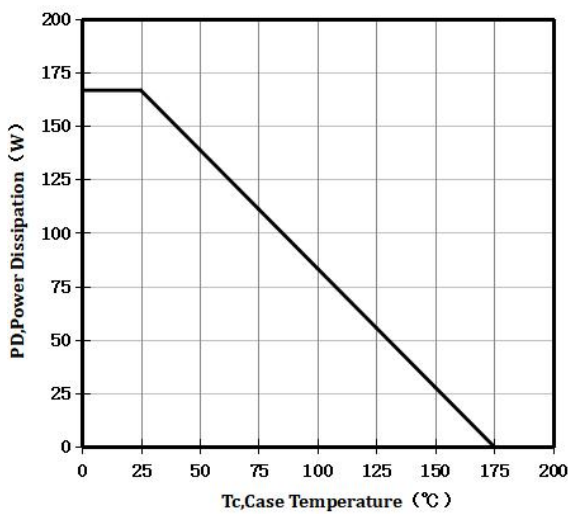

Figure 5 Power De-rating

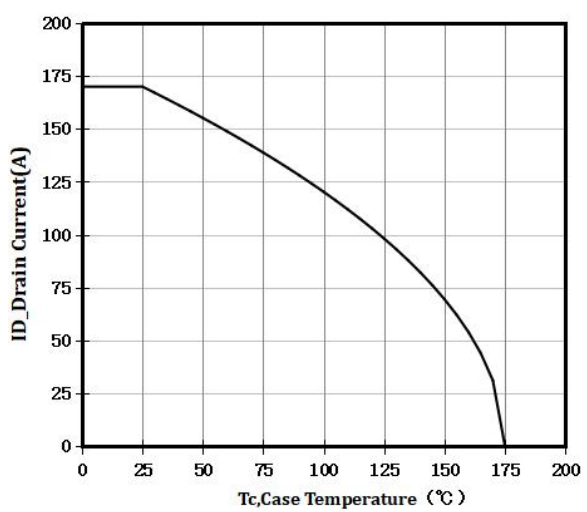

Figure 6 Current De-rating

5 Typical characteristics diagrams(continues)

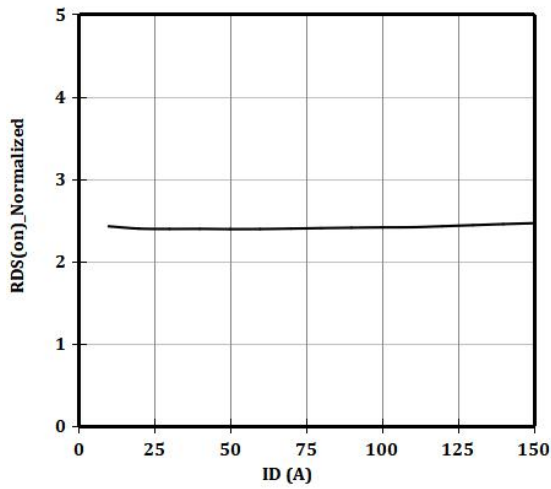

Figure 7 Rds(on)- Drain Current

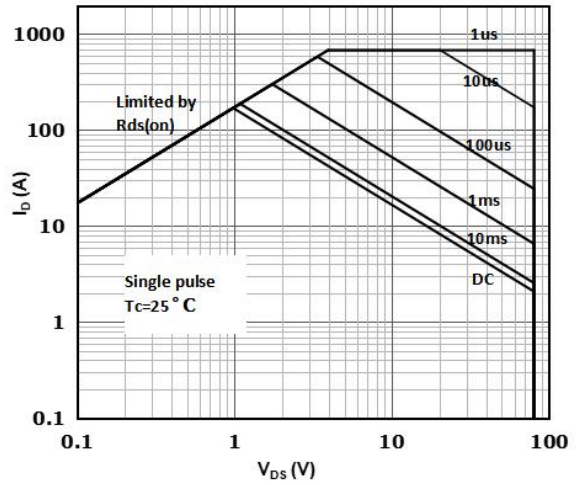

Figure 8 Safe Operation Area

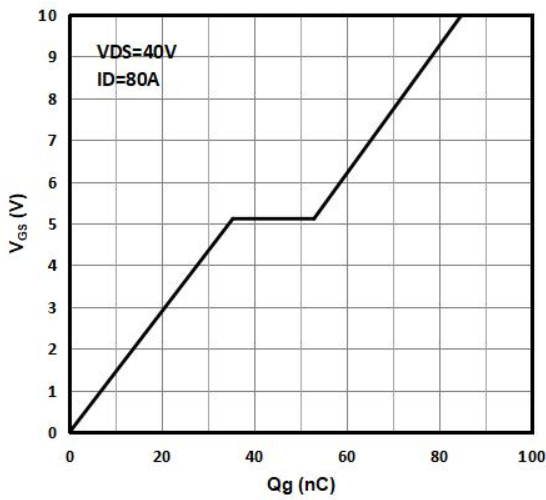

Figure 9 Gate Charge

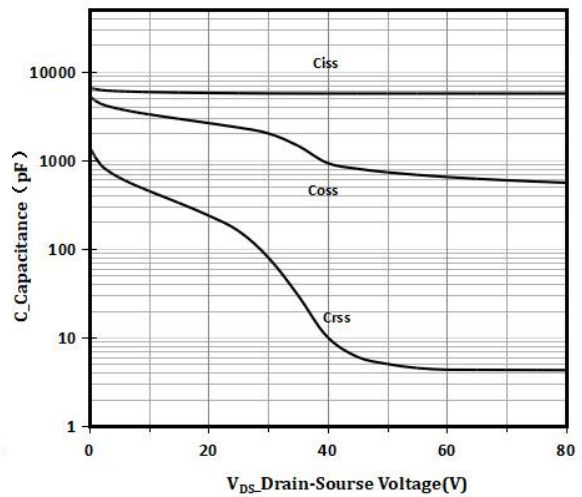

Figure 10 Capacitance vs Vds

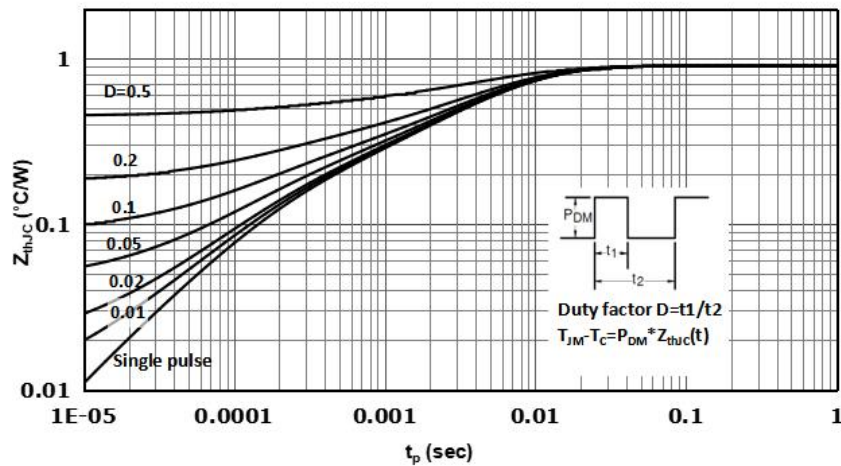
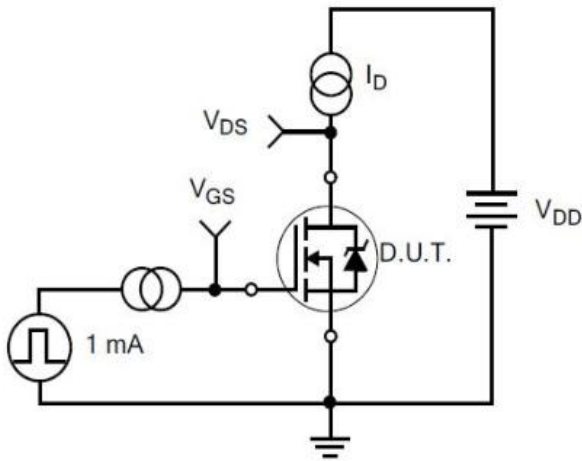
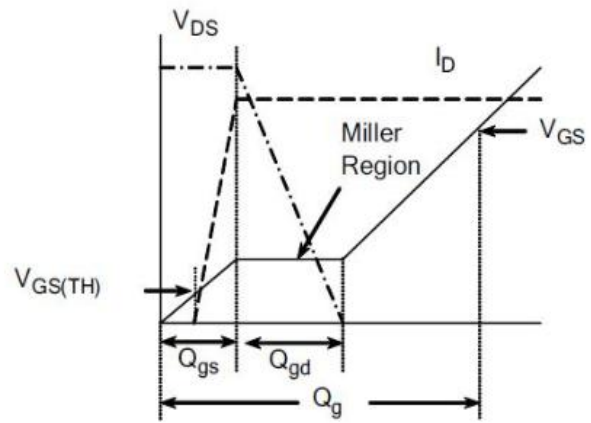

Figure 11 Normalized Maximum Transient Thermal Impedance

6 Typical Test Circuit and Waveform



1) Gate Charge Test Circuit



2) . Gate Charge Waveform

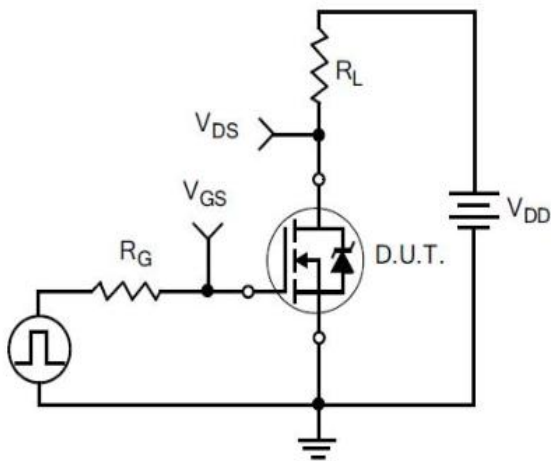

3) Resistive Switching Test Circuit

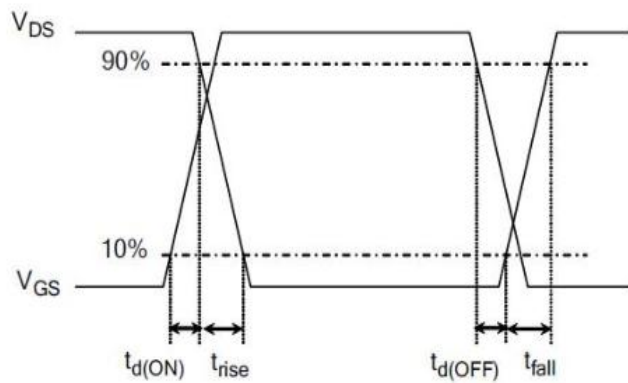

4) Resistive Switching Waveforms

5 Typical Test Circuit and Waveform(continues)

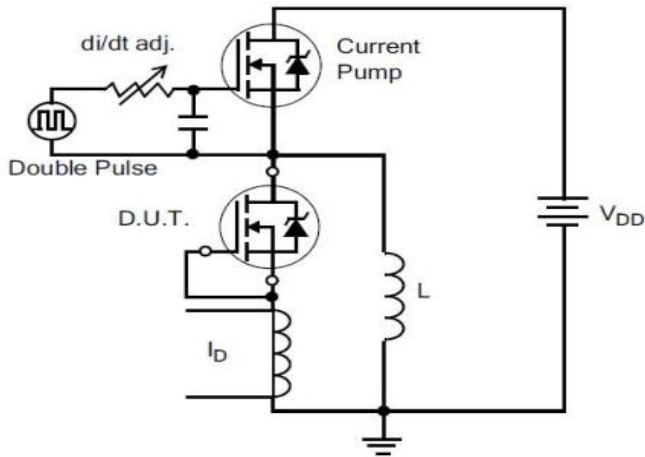

5) Diode Reverse Recovery Test Circuit

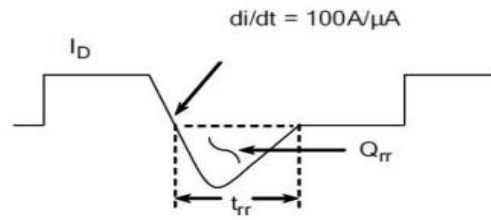

6) Diode Reverse Recovery Waveform

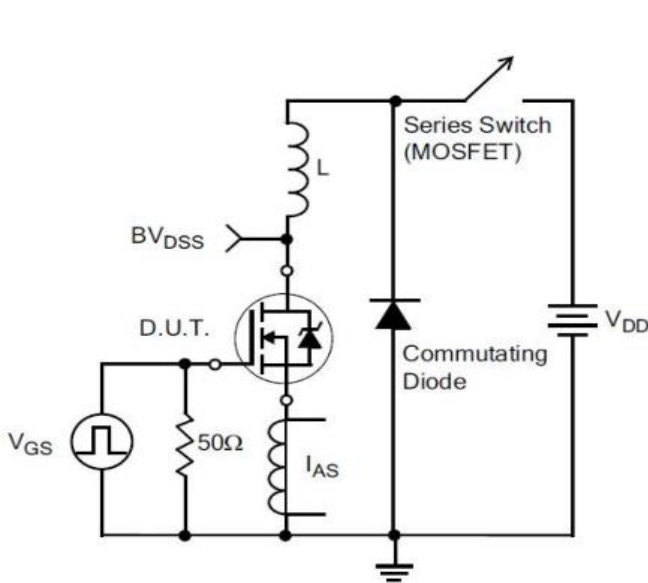

7) . Unclamped Inductive Switching Test Circuit

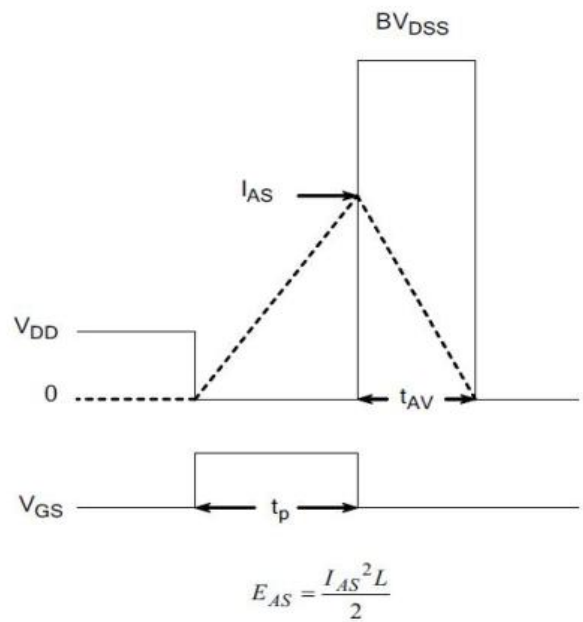

8) Unclamped Inductive Switching Waveforms

6 Product Names Rules

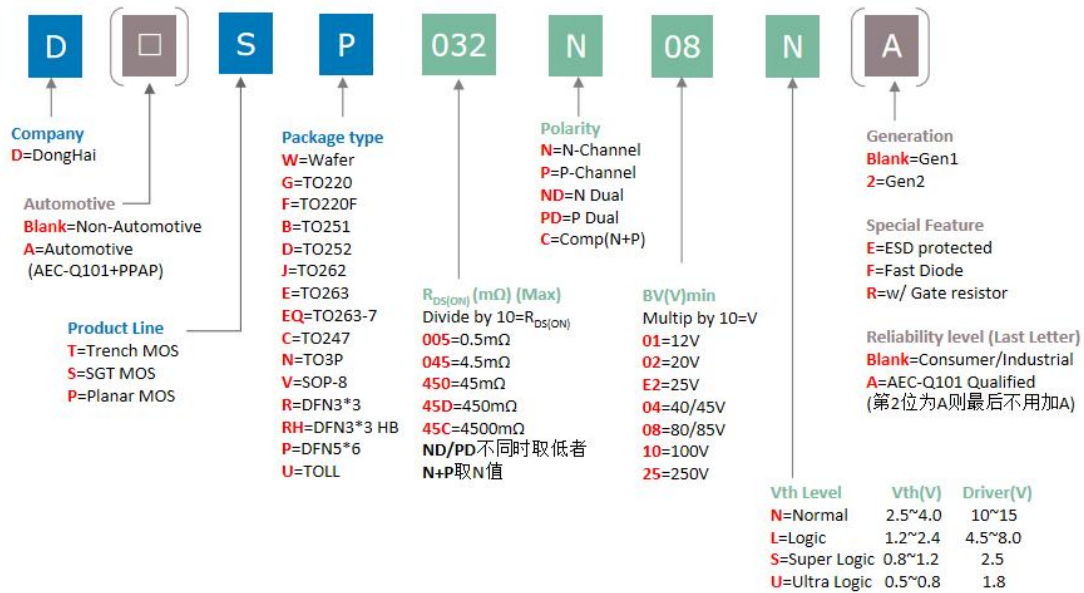

7 Product Specifications and Packaging Models

Product Model	Package Type	Mark Name	RoHS	Package	Quantity
DSP032N08NA	DFN5*6-8	DSP032N08NA	Pb-free	Tape & Reel	3000/box

8 Dimensions

PPAK5x6 PACKAGE INFORMATION

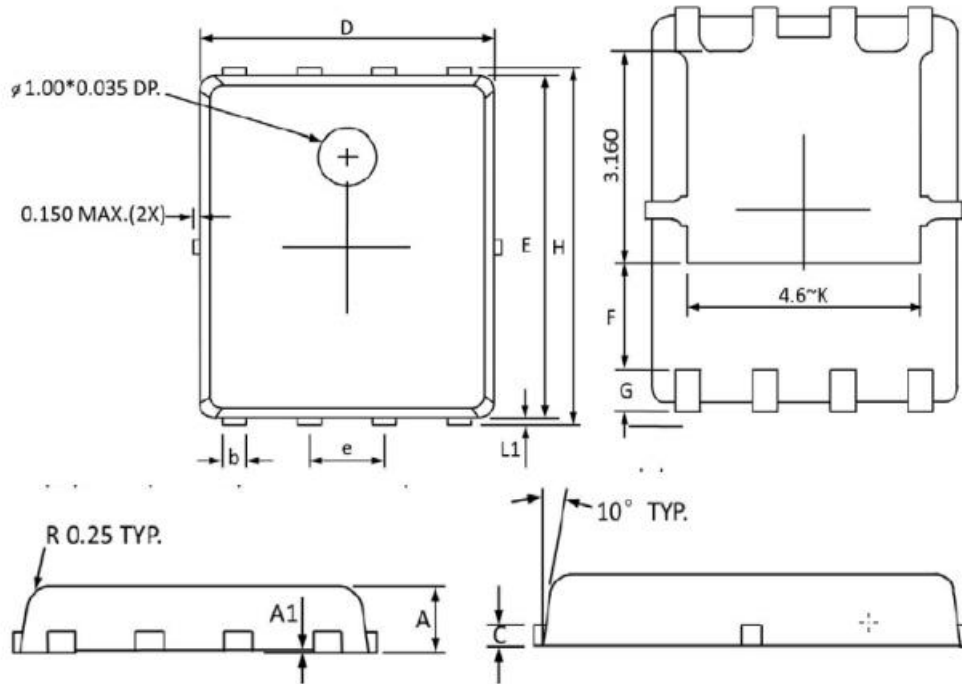

Symbol	Dimensions In Millimeters		Dimensions In Inches	
	Min	Max	Min	Max
A	0.800	1.000	0.032	0.039
A1	0.000	0.005	0.000	0.000
b	0.350	0.490	0.014	0.019
C	0.254 Ref		0.254 Ref	
D	4.900	5.100	0.193	0.200
E	5.700	5.900	0.225	0.232
e	1.27 BSC		1.27 BSC	
F	1.600 Ref		1.600 Ref	
G	0.600 Ref		0.600 Ref	
H	5.950	6.200	0.235	0.244
L1	0.100	0.180	0.004	0.007
K	3.200 Ref		3.200 Ref	

9 Attentions

- Jiangsu Donghai Semiconductor Technology CO.,LTD. reserves the right to change the specification without prior notice! The customer should obtain the latest version of the information before making the order and verify that the information is complete and up to date.
- It is the responsibility of the purchaser for any failure or failure of any semiconductor product under certain conditions. It is the responsibility of the purchaser to comply with safety standards and to take safety measures in the system design and machine manufacturing of Donghai products in order to avoid potential risk of failure. Injury or property damage.
- Product promotion is endless, our company will be dedicated to provide customers with better products.

10 Appendix

Revision history:

Date	REV.	Description	Page
2022.11.10	1.0	Original	9