

### Features

- **AEC-Q101 qualified**
- Low on resistance
- Low reverse transfer capacitances
- 100% single pulse avalanche energy test
- 100% ΔVDS test
- Pb-Free plating / Halogen-Free / RoHS compliant

### Key Parameters

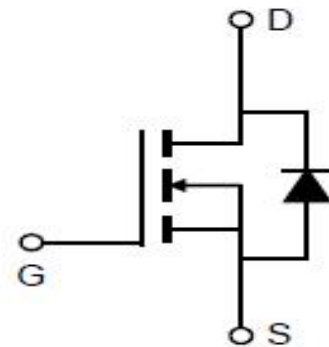
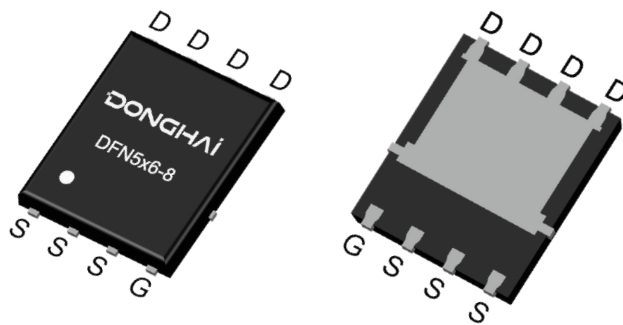
$V_{DS}$	100V
$R_{DS(on)typ.}$	5.2mΩ
$I_D$	95A
$V_{th}$	1.7V
$C_{iss@10V}$	2690pF
$Q_{gd}$	12nC

### Applications

- Motor Control and Drive
- Charge/Discharge for Battery Management System
- Synchronous Rectifier for SMPS
- Automotive application



### DFN5\*6



### Marking & Packing Information

Part #	Package	Marking	Tube/Reel	Qty(pcs)
DSP070N10L3A	DFN5*6	DSP070N10L3A	Tape & Reel	3000/box

### Absolute Maximum Ratings

Parameter	Symbol	Value	Unit
Drain-source voltage	$V_{DS}$	100	V
Gate-Source voltage	$V_{GS}$	±20	V
Continuous drain current $T_C = 25^\circ\text{C}$ $T_C = 100^\circ\text{C}$	$I_D$	95 67	A
Pulsed drain current ( $T_C = 25^\circ\text{C}$ , $t_p$ limited by $T_{jmax}$ )	$I_{D\ pulse}$	380	A
Avalanche energy, single pulse ( $L=0.5\text{mH}$ , $R_g=25\Omega$ )	$E_{AS}$	272	mJ
Power dissipation $T_C = 25^\circ\text{C}$	$P_{tot}$	94	W
Operating junction and storage temperature	$T_j, T_{stg}$	-55...+175	$^\circ\text{C}$

### Thermal Resistance

Parameter	Symbol	Max	Unit
Thermal resistance, junction – case.	$R_{thJC}$	1.60	$^\circ\text{C}/\text{W}$

### Electrical Characteristic (at $T_j = 25^\circ\text{C}$ , unless otherwise specified)

#### Static Characteristic

Parameter	Symbol	Value			Unit	Test Condition
		min.	typ.	max.		
Drain-source breakdown voltage	$BV_{DSS}$	100	-	-	V	$V_{GS}=0\text{V}, I_D=250\mu\text{A}$
Gate threshold voltage	$V_{GS(th)}$	1.2	1.7	2.2	V	$V_{DS}=V_{GS}, I_D=250\mu\text{A}$
Zero gate voltage drain current	$I_{DSS}$	-	-	1 100	$\mu\text{A}$	$V_{DS}=100\text{V}, V_{GS}=0\text{V}$ $T_j=25^\circ\text{C}$ $T_j=125^\circ\text{C}$
Gate-source leakage current	$I_{GSS}$	-	-	100	nA	$V_{GS}=20\text{V}, V_{DS}=0\text{V}$
Drain-source on-state resistance	$R_{DS(on)}$	-	5.2 6.7	6.2 9.0	$\text{m}\Omega$	$V_{GS}=10\text{V}, I_D=60\text{A},$ $T_j=25^\circ\text{C}$ $V_{GS}=4.5\text{V}, I_D=60\text{A}$

**Dynamic Characteristic**

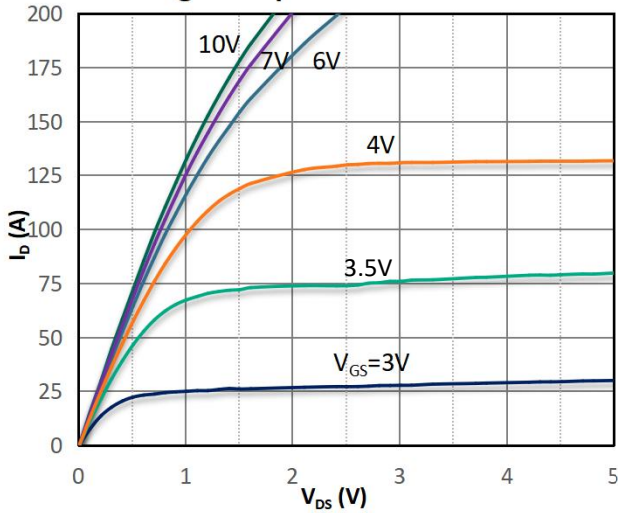
Parameter	Symbol	Value			Unit	Test Condition
		min.	typ.	max.		
Input Capacitance	$C_{iss}$	-	2690	-	pF	$V_{GS}=0V, V_{DS}=50V, f=1MHz$
Output Capacitance	$C_{oss}$	-	713	-		
Reverse Transfer Capacitance	$C_{rss}$	-	47	-		
Gate Total Charge	$Q_G$	-	50	-	nC	$V_{GS}=10V, V_{DS}=50V, I_D=60A, f=1MHz$
Gate-Source charge	$Q_{gs}$	-	11	-		
Gate-Drain charge	$Q_{gd}$	-	12	-		
Turn-on delay time	$t_{d(on)}$	-	11	-	ns	$V_{GS}=10V, V_{DD}=50V, R_{G\_ext}=3\Omega, I_D=60A$
Rise time	$t_r$	-	28	-		
Turn-off delay time	$t_{d(off)}$	-	37	-		
Fall time	$t_f$	-	15	-		

**Body Diode Characteristic**

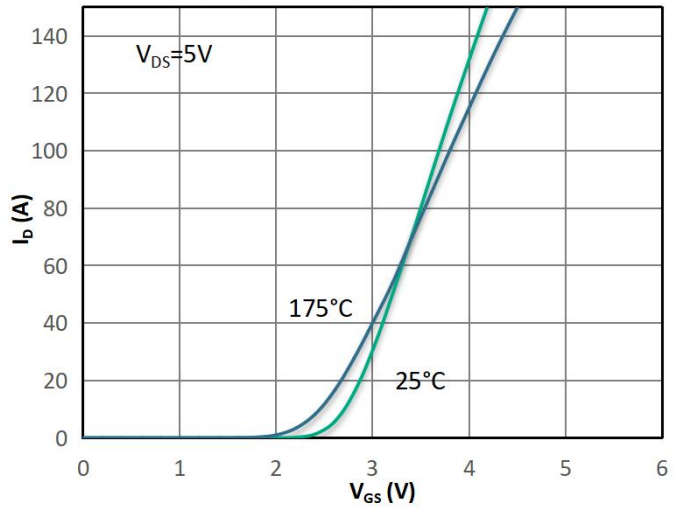
Parameter	Symbol	Value			Unit	Test Condition
		min.	typ.	max.		
Diode Max Current	$I_S$		-	95	A	-
Diode Forward Voltage	$V_{SD}$	-	-	1.2	V	$V_{GS}=0V, I_{SD}=60A$
Diode Reverse Recovery Time	$t_{rr}$	-	55	-	ns	$T_j=25^\circ C, I_F=40A, dI/dt=100A/\mu s$
Diode Reverse Recovery Charge	$Q_{rr}$	-	90	-	nC	

**Typical Characteristics Diagram**

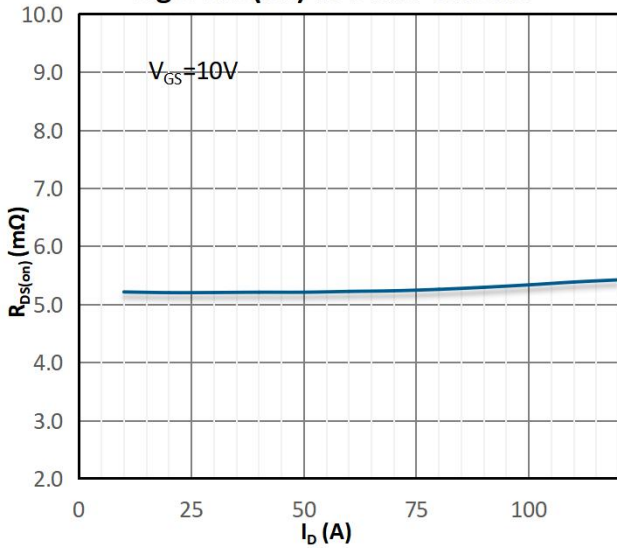
**Fig1. Output Characteristics**



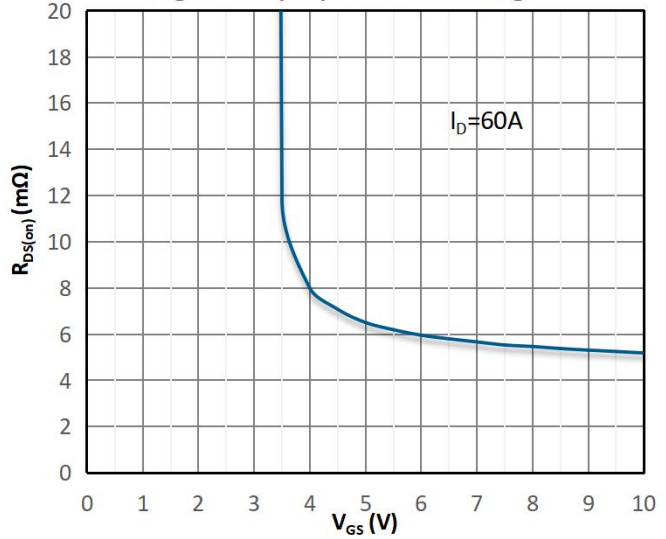
**Fig2. Transfer Characteristics**



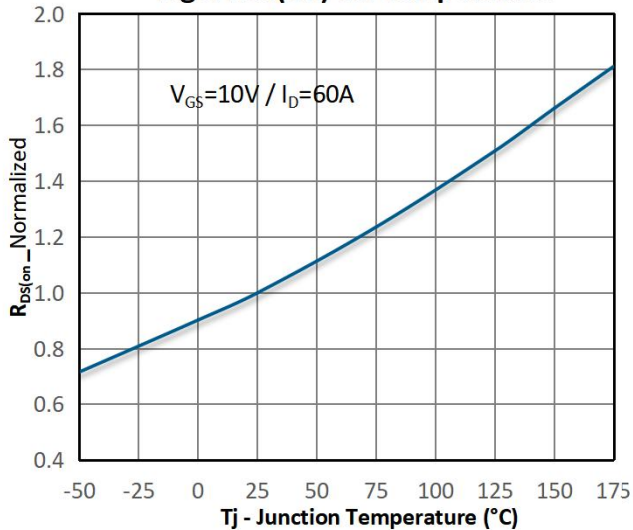
**Fig3. Rds(on) vs Drain Current**



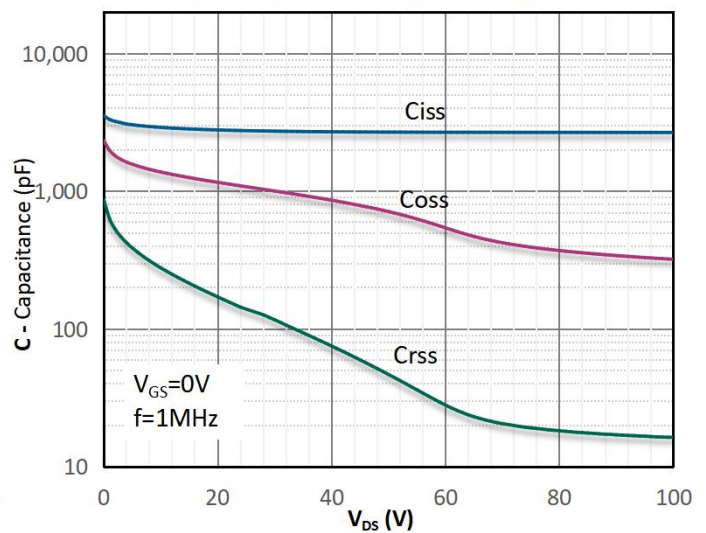
**Fig 4. Rds(on) vs Gate Voltage**



**Fig5. Rds(on) vs. Temperature**

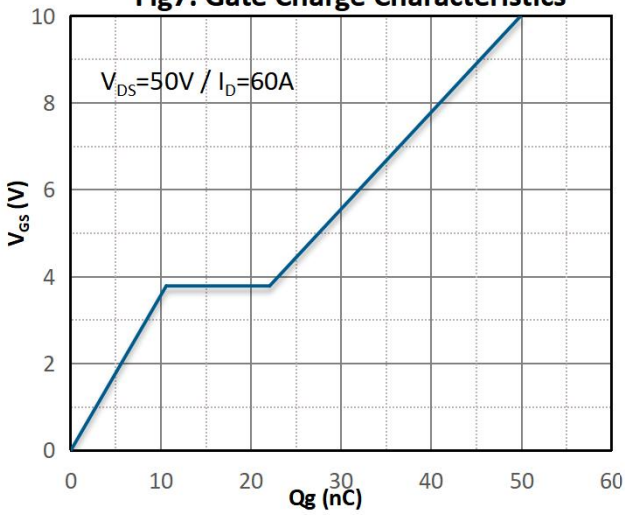


**Fig6. Capacitance Characteristics**

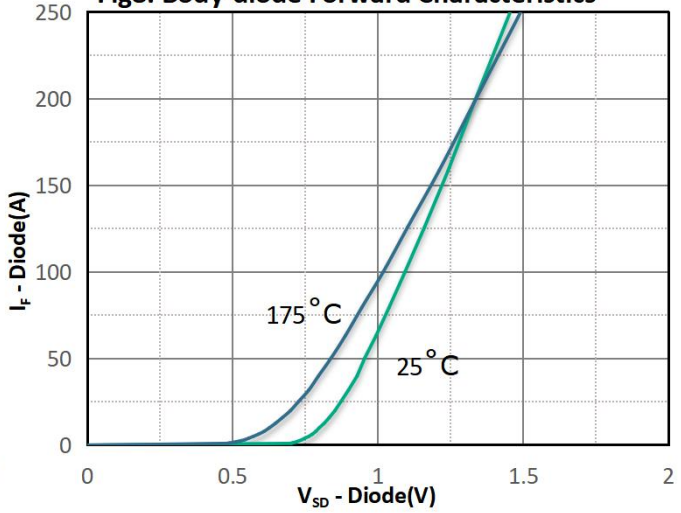


**Typical Characteristics Diagram**

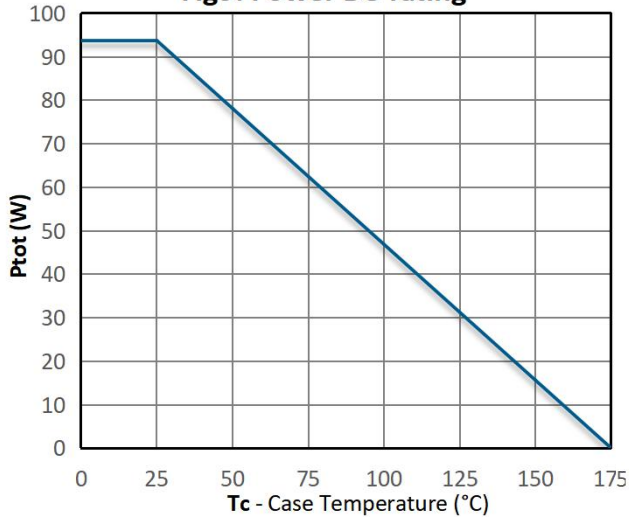
**Fig7. Gate Charge Characteristics**



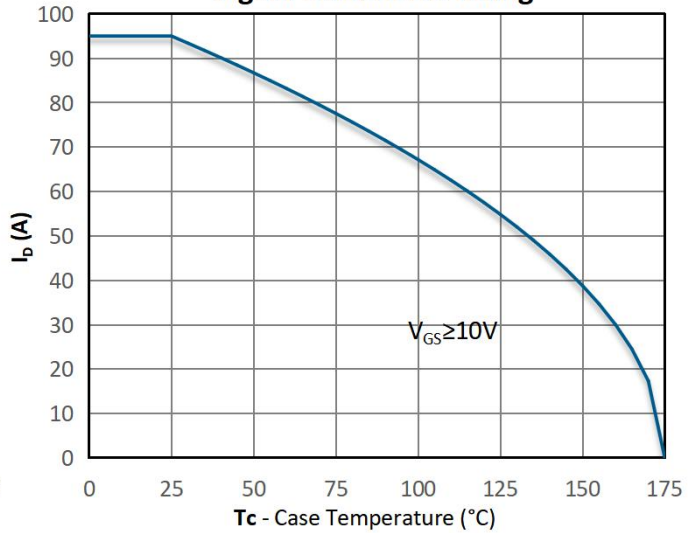
**Fig8. Body-diode Forward Characteristics**



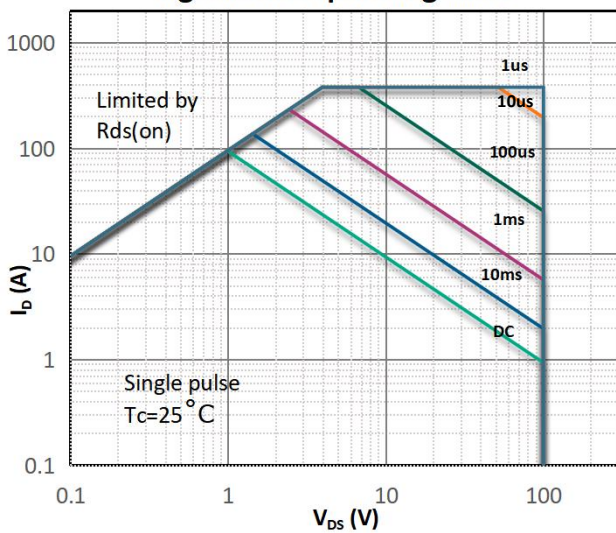
**Fig9. Power De-rating**



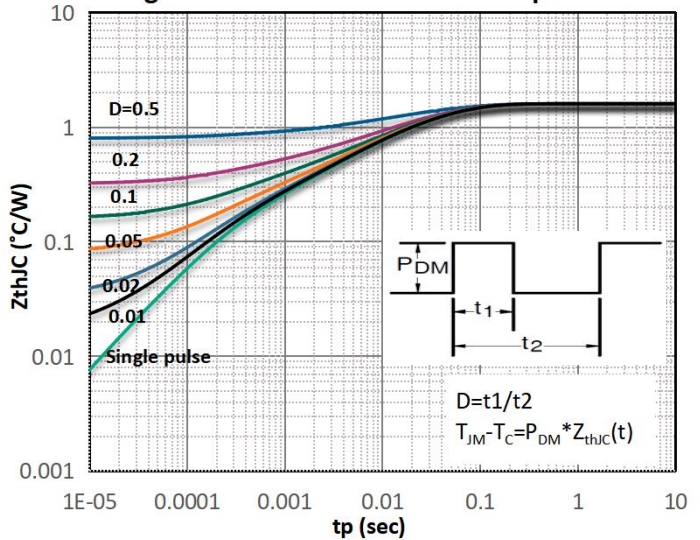
**Fig10. Current De-rating**



**Fig11. Safe Operating Area**

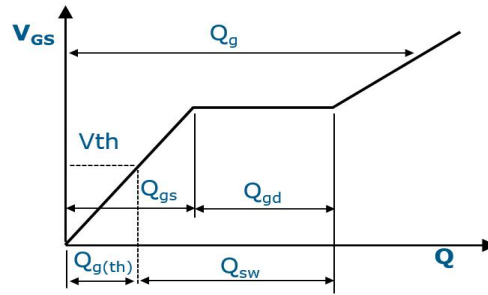
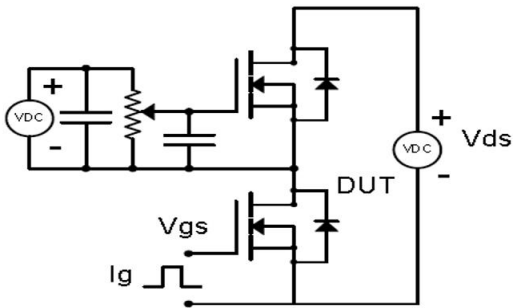


**Fig12. Max. Transient Thermal Impedance**

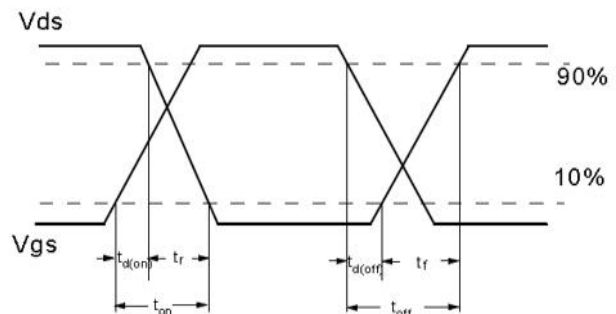
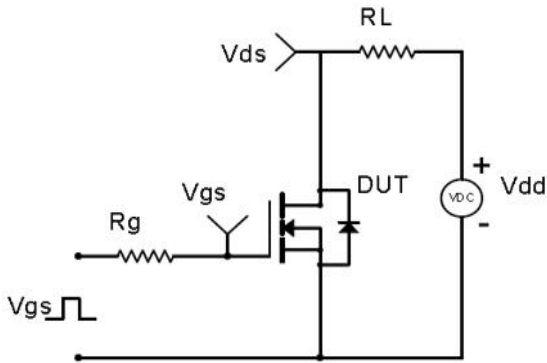


**Test Circuit & Waveform**

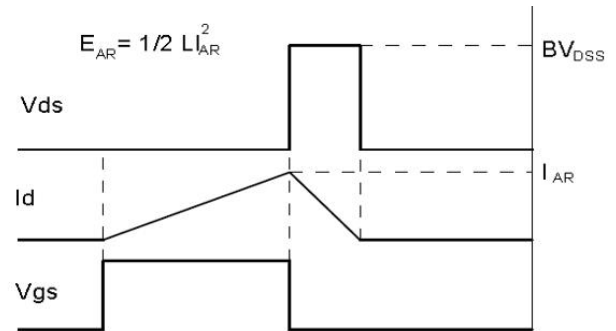
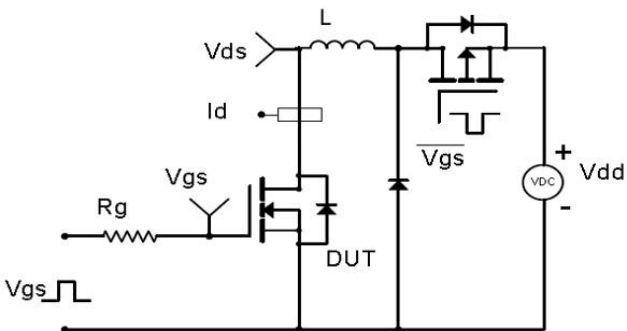
**Gate Charge Test Circuit & Waveform**



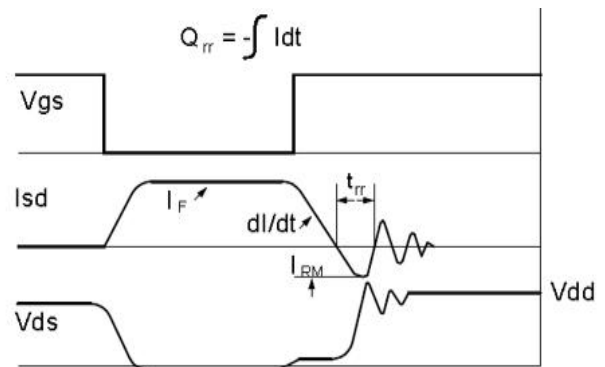
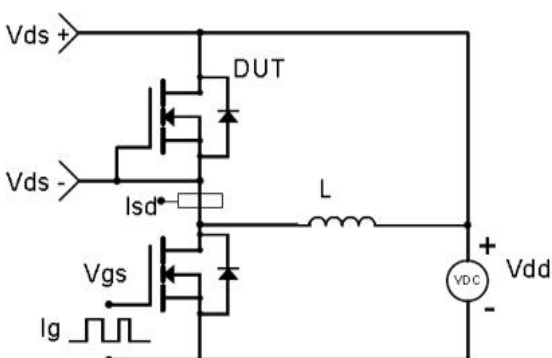
**MOSFET Switching Test Circuit & Waveform**



**E<sub>AS</sub> Test Circuit & Waveform**

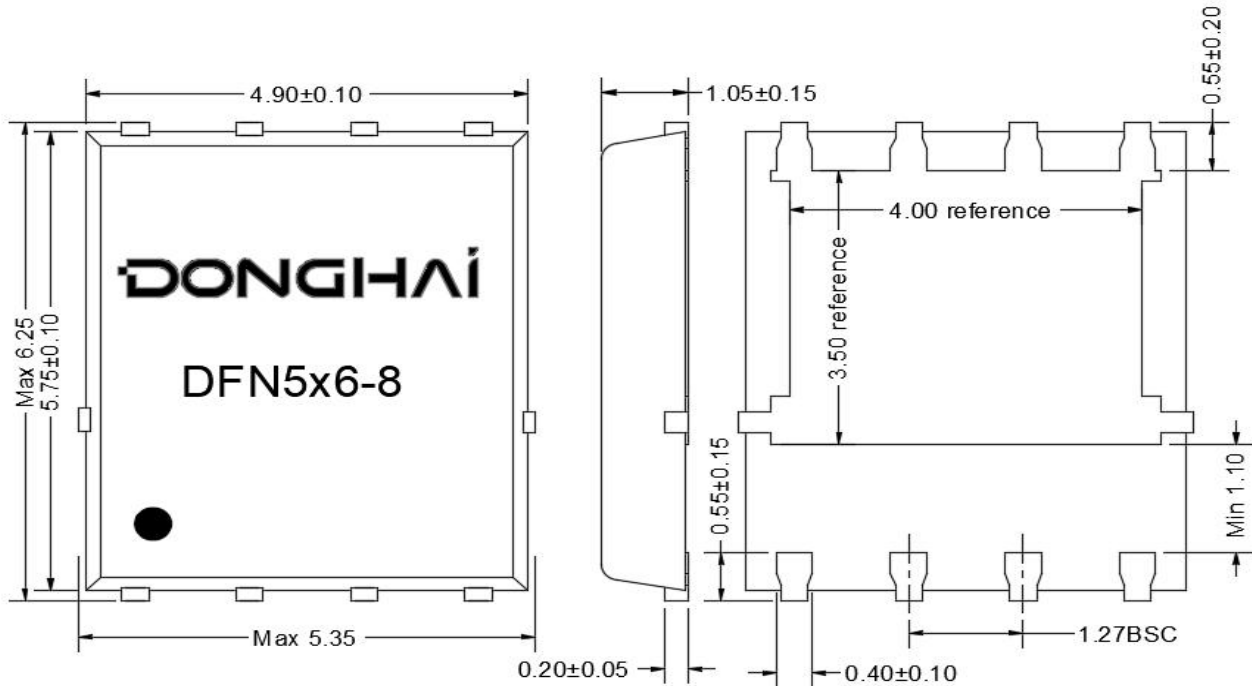


**Diode Recovery Test Circuit & Waveform**



**Package Outline : DFN5\*6-8**

\*Dimensions in mm



**Revision History**

Revison	Date	Major changes
1.0	2023/10/7	Release of formal version

**Disclaimer**

Unless otherwise specified in the datasheet, the product is designed and qualified as a standard commercial product and is not intended for use in applications that require extraordinary levels of quality and reliability, such as aviation, aerospace, life-support devices or systems.

Any and all semiconductor products have certain probability to fail or malfunction, which may result in personal injury, death or property damage. Customer are responsible for providing adequate safe measures when design their systems.

DONGHAI Semiconductor reserves the right to improve product design, function, reliability without notice. Copy Rights@Jiangsu Donghai Semiconductor Co. Ltd.